



**Time-to-Digital-Converter**  
Preliminary Datasheet

## **TDC-GP22**

**Universal 2-Channel Time-to-Digital Converter  
dedicated to Ultrasonic Heat & Water Meters**

2nd April 2012

Document-No.: DB\_GP22\_e V0.3

**Published by acam-messelectronic gmbh**

© **acam-messelectronic gmbh 2012**

### **Disclaimer / Notes**

The information provided by this preliminary datasheet is believed to be close to the final product. However, it is theoretical and no responsibility is assumed by acam for its use, nor for any infringements of patents or other rights of third parties that may result from its use. The information is subject to change without notice and is provided „as is“ without warranty of any kind (expressed or implied). Picostrain is a registered trademark of acam. All other brand and product names in this document are trademarks or service marks of their respective owners.

### **Support**

For a complete listing of direct sales, distributors and sales representatives visit the acam website at:

<http://www.acam.de/company/distributors>

For technical support you can contact the acam support team in the headquarter in Germany or the Distributor in your country. The contact details of acam in Germany are:

sales@acam.de or by phone +49-7244-74190.

## Table of Contents

<b>1 Overview</b>	<b>1-1</b>
<b>2 Characteristics &amp; Specifications</b>	<b>2.1 Electrical Characteristics</b> 2-2
	<b>2.2 Converter Specification</b> 2-4
	<b>2.3 Timings</b> 2-6
	<b>2.4 Pin Description</b> 2-8
	<b>2.5 Package Drawings</b> 2-9
	<b>2.6 Power Supply</b> 2-11
<b>3 Registers &amp; Communication</b>	<b>3.1 Configuration registers</b> 3-2
	<b>3.2 Read registers</b> 3-14
	<b>3.3 EEPROM</b> 3-16
	<b>3.4 SPI-interface</b> 3-17
<b>4 Converter Frontend</b>	<b>4.1 TDC - Measure Mode 1</b> 4-2
	<b>4.2 TDC - Measure Mode 2</b> 4-8
	<b>4.3 Analog Input Section</b> 4-15
	<b>4.4 First Wave Mode</b> 4-17
	<b>4.5 Temperature Measurement</b> 4-21
<b>5 Details and Special Functions</b>	<b>5.1 Oscillator</b> 5-2
	<b>5.2 Fire-pulse Generator</b> 5-5
	<b>5.3 Fast Initialization</b> 5-8
	<b>5.4 Noise Unit</b> 5-8
<b>6 Applications</b>	<b>6-2</b>
<b>7 Miscellaneous</b>	<b>7.1 Bug Report</b> 7-1



# 1 Overview

TDC-GP22 is next generation's upgrade for TDC-GP21. It is a 100% pin-to-pin and functional compatible upgrade of TDC-GP21, with an extended functionality. Especially the new first-wave detection capability makes the TDC-GP22 perfectly suited for ultrasonic water meters with their high dynamics. The programmable offset range of the comparator is increased to  $\pm 35$  mV and the offset is automatically set back to zero after the first wave detection. Measuring the relative pulse width of the first wave gives the user an indication of the strength of the received signal. This can be used for adopting the system to longterm signal attenuation or for bubble detection. The multi-hit data processing and data read-out is simplified compared to TDC-GP21.

All in all, the TDC-GP221 is a further improvement and simplification for the design of ultrasonic heat meters and a necessary step for compact ultrasonic water meters.

## 1.1 Features

### Measure Mode 2

- 1 channel with typ. 90 ps resolution
- Double resolution mode with 45 ps, Quad resolution mode with 22 ps resolution
- Measurement range 500 ns to 4 ms
- 3-fold multihit capability with **automatic processing of all 3 data**

### Analog Input Circuit

- Chopper-stabilized low-offset comparator, programmable,  $\pm 35$  mV
- **First-wave detection:** offset set zero automatically after first wave, hit selection relative to first wave
- **First-wave pulse-width measurement** for signal monitoring and bubble detection
- Integrated analog switches for input selection
- External circuit is reduced to 2 resistors and 2 capacitors

### Temperature Measurement Unit

- 2 or 4 sensors, PT500/PT1000 or higher
- Schmitt trigger integrated
- 16-Bit eff. with external Schmitt-trigger, 17.5-Bit eff. with integrated low noise Schmitt-trigger

- Ultra low current (0.08  $\mu$ A when measuring every 30 seconds)

### Special Functions

- Fire pulse generator, up to 127 pulses
- Trigger to rising and/or falling edge
- Precise stop enable by windowing
- Low-power 32 kHz oscillator (500 nA)
- Clock calibration unit
- 7x32 Bit EEPROM

### Measure Mode 1

- 2 channels with typ. 90 ps resolution
- 1-channel double resolution with typ. 45 ps
- Range 3.5 ns (0 ns) to 2.5  $\mu$ s
- 20 ns pulse-pair resolution, 4-fold multihit
- Up to 1 million measurements per second in measure mode 1

### General

- 4-wire SPI interface
- 1 MHz continuous data rate max.
- I/O voltage 2.5 V to 3.6 V
- Core voltage 2.5 V to 3.6 V
- Temperature range – 40 °C to +125 °C
- QFN 32 package

## 1 Overview

### 1.2 Blockdiagram

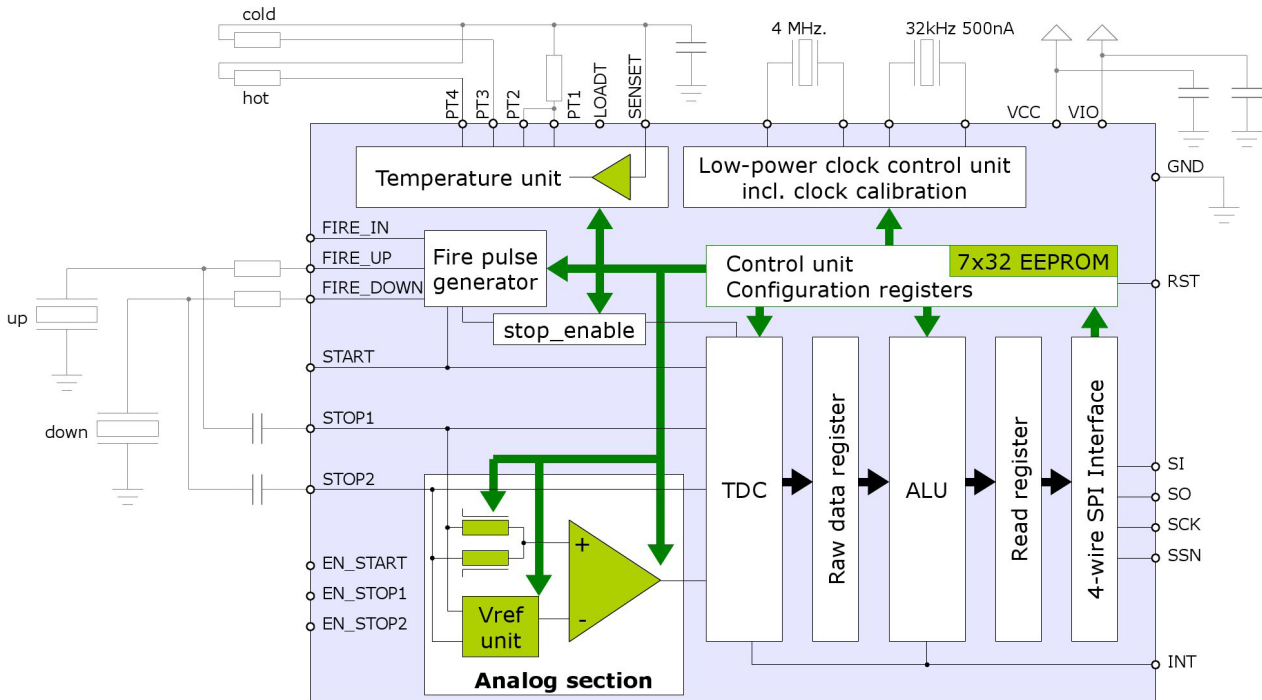

### 1.3 Ordering Numbers

Part#	Package	Package Qty; Carrier	Order number
TDC-GP22	QFN32	5000/3000; T&R	MNR 1950
TDC-GP22	QFN32	490; Tray	MNR 1949
GP22-EVA-KIT	System	1; Box	MNR 1951

This product is RoHS compliant and does not contain any Pb.

<b>2</b>	<b>Characteristics &amp; Specifications.....</b>	<b>2-2</b>
<b>2.1</b>	<b>Electrical Characteristics .....</b>	<b>2-2</b>
<b>2.2</b>	<b>Converter Specification .....</b>	<b>2-4</b>
<b>2.3</b>	<b>Timings.....</b>	<b>2-6</b>
<b>2.4</b>	<b>Pin Description.....</b>	<b>2-8</b>
<b>2.5</b>	<b>Package Drawings .....</b>	<b>2-9</b>
<b>2.6</b>	<b>Power Supply .....</b>	<b>2-11</b>

## 2 Characteristics & Specifications

### 2.1 Electrical Characteristics

#### Absolute Maximum Ratings

Supply voltage

$V_{CC}$  vs. GND - 0.3 to 4.0 V

$V_{IO}$  vs. GND - 0.3 to 4.0 V

$V_{in}$  - 0.5 to  $V_{CC} + 0.5$  V

Storage temperature ( $T_{stg}$ ) - 55 to 150 °C

ESD rating (HBM), each pin > 2 kV

Junction temperature ( $T_j$ ) max. 125 °C

#### Recommended Operating Conditions

Symbol	Parameter	Conditions	Min	Typ	Max	Unit
$V_{CC}$	Core supply voltage*	$V_{IO} = V_{CC}$	2.5		3.6	V
$V_{IO}$	I/O supply voltage		2.5		3.6	V
$t_{ri}$	Normal input rising time				200	ns
$t_{fa}$	Normal input falling time				200	ns
$t_{ri}$	Schmitt trigger rising time				5	ms
$t_{fa}$	Schmitt trigger falling time				5	ms
$T_a$	Ambient temperature	$T_j$ must not exceed 125°C	-40		125	°C
$R_{th(j-a)}$	Thermal resistance	junction-ambient		28		K/W

\*including the oscillator pins XIN, XOUT, Clk32In, Clk32Out

#### DC Characteristics ( $V_{IO} = V_{CC} = 3.0$ V, $T_j = -40$ to $+85$ °C)

Symbol	Parameter	Conditions	Min	Typ	Max	Unit
$I_{32}$	Current 32 kHz	$I_{CC} + I_{IO}$ , only 32 kHz oscillator running		1.0		µA
$I_{hs}$	Current 4 Mhz oscillator	$V_{CC} = V_{IO} = 3.6$ V = 3.0 V off		200 130 < 1		µA µA nA
$I_{tmu}$	Current time measuring unit	only during active time measurement		4		mA
$I_{ddq}$	Quiescent current	all clocks off, @ 85 °C		< 0.1		µA
$I_o$	Operating current	TOF-UP/DOWN, 1/s Temperature average, PT1000, 1/30s		1.1 0.15		µA



## 2 Characteristics & Specifications

Symbol	Parameter	Conditions	Min	Typ	Max	Unit
$V_{oh}$	High level output voltage	$I_{oh} = \text{tbd mA}$ , $V_{io} = \text{Min.}$	$0.8V_{io}$			V
$V_{ol}$	Low level output voltage	$I_{ol} = \text{tbd mA}$ , $V_{io} = \text{Min.}$			$0.2V_{io}$	V
$V_{ih}$	High level input voltage	LVTTTL Level, $V_{io} = \text{Max.}$	$0.7V_{io}$			V
$V_{il}$	Low level input voltage	LVTTTL Level, $V_{io} = \text{Min.}$			$0.3V_{io}$	V
$V_{th}$	High level Schmitt trigger voltage		$0.7V_{io}$			V
$V_{tl}$	Low level Schmitt trigger voltage				$0.3V_{io}$	V
$V_h$	Schmitt trigger hysteresis			0.28		V

### Terminal Capacitance

Symbol	Terminal	Condition	Rated Value			Unit
			Min.	Typ.	Max.	
$C_i$	Digital input	measured @ $V_{cc} = V_{io}$ , $f = 1 \text{ MHz}$ , $T_a = 25^\circ\text{C}$		7		pF
$C_o$	Digital output					
$C_{io}$	Bidirectional			9		
	PT ports			t.b.d.		
	Analog in			t.b.d.		

### Analog Frontend

Symbol	Terminal	Condition	Rated Value			Unit
			Min.	Typ.	Max.	
	Comparator input offset voltage (chopper stabilized)			< 1	2	mV
$R_{dson(AS)}$	Switch-on resistance of analog switches at STOP1/STOP2 inputs			200		Ohm
$R_{dson(FIRE)}$	Switch-on resistance of FIRE_UP, FIRE_DOWN output buffers	Symmetrical outputs, $R_{dson(HIGH)} = R_{dson(LOW)}$		4		Ohm
$I_{fire}$	Output current FIRE_UP, FIRE_DOWN output buffers			96		mA

### EEPROM

Symbol	Terminal	Condition	Minimum Value	Unit
	Data retention @ $85^\circ\text{C}$	normal	10	years
		with Error correction	practically endless	

## 2 Characteristics & Specifications

### 2.2 Converter Specification

**Time Measuring Unit ( $V_{IO} = V_{CC} = 3.0\text{ V}$ ,  $T_j = 25^\circ\text{C}$ )**

Symbol	Terminal	Condition	Rated Value			Unit
			Min.	Typ.	Max.	
LSB	Resolution (BIN-Size)	Measure Mode 1 & 2: DOUBLE_RES = 0		90		ps
		DOUBLE_RES = 1		45		
		Measure mode 2: QUAD_RES = 1		22		ps
$\sigma$	Standard deviation	Measure Mode 1 & 2: DOUBLE_RES = 0		t.b.d		ps
		DOUBLE_RES = 1				
		Measure mode 2: QUAD_RES = 1		t.b.d		ps
$t_m$	Measuring range	Measure mode 1	3.5 ns		2.4 $\mu\text{s}$ =26224 *LSB	
		Measure mode 2	500 ns		4 ms	
INL	Integral Non-linearity			< 0.1		LSB
DNL	Differential Non-linearity			< 0.8		LSB

## 2 Characteristics & Specifications

### Temperature Measuring Unit<sup>1</sup>

Symbol	Terminal		Internal Schmitt-Trigger		external Schmitt-Trigger <sup>2</sup>		Unit
			PT500	PT1000	PT500	PT1000	
	Resolution RMS		17.5	17.5	16.0	16.0	Bit
	SNR		105	105	96	96	dB
	Absolute Gain <sup>3</sup>		0.9912	0.9931	0.9960	0.9979	
		3.6 V	0.9923	0.9940	0.9962	0.9980	
	Absolute Gain vs. $V_{io}$ <sup>3</sup>	3.0 V	0.9912	0.9931	0.9960	0.9979	
		2.5 V	0.9895	0.9915	0.9956	0.9979	
	Gain-Drift vs. $V_{io}$		0,25	0.23	0.06	0.04	%/V
	max. Gain Error [@ $d\theta = 100$ K]		0,05%	0,05%	0,02%	< 0.01%	
	Gain-Drift vs. Temp		0.022	0.017	0.012	0.0082	%/10 K
	Gain-Drift vs. $V_{io}$				0,08		%/V
	Initial Zero Offset		< 20	<10	< 20	< 10	mK
	Offset Drift vs. Temp		< 0.05	< 0.03	< 0,012	< 0.0082	mK/ °C
	PSRR				>100		dB

<sup>1</sup> All values measured at  $V_{io} = V_{cc} = 3.0$  V,  $C_{load} = 100$  nF for PT1000 and 200 nF for PT500 (COG-type)

<sup>2</sup> measured with external 74AHC14 Schmitt-trigger

<sup>3</sup> compared to an ideal gain of 1

## 2 Characteristics & Specifications

### 2.3 Timings

At  $V_{CC} = 3.0\text{ V} \pm 0.3\text{ V}$ , ambient temperature  $-40\text{ }^{\circ}\text{C}$  to  $+85\text{ }^{\circ}\text{C}$  unless otherwise specified

#### Oscillator

Symbol	Parameter	Min.	Typ.	Max.	Unit
Clk32	32 kHz reference oscillator		32,768		kHz
$t_{32st}$	32 kHz oscillator start-up time after power-up		3		s
ClkHS	High-speed reference oscillator	2	4	8	MHz
$t_{oszst}$	Oscillator start-up time with ceramic resonator		100		$\mu\text{s}$
$t_{oszst}$	Oscillator start-up time with crystal oscillator		3		ms

#### Serial Interface

Symbol	Parameter	Max. @ $V_{IO} =$		Unit
		2.5 V	3.3 V	
$f_{clk}$	Serial clock frequency	15	20	MHz

Symbol	Parameter	Min. @ $V_{IO} =$		Unit
		2.5 V	3.3 V	
$t_{pwh}$	Serial clock, pulse width high	30	25	ns
$t_{pwl}$	Serial clock, pulse width low	30	25	ns
$t_{sussn}$	SSN enable to valid latch clock	40	10	ns
$t_{pwssn}$	SSN pulse width between write cycles	50	40	ns
$t_{hssn}$	SSN hold time after SCLK falling	40	25	ns
$t_{sud}$	Data set-up time prior to SCLK falling	5	5	ns
$t_{hd}$	Data hold time before SCLK falling	5	5	ns

Symbol	Parameter	Max. @ $V_{IO} =$		Unit
		2.5 V	3.3 V	
$t_{vd}$	Data valid after SCLK rising	20	16	ns

Serial Interface (SPI compatible, Clock Phase Bit =1, Clock Polarity Bit =0):

## 2 Characteristics & Specifications

Figure 2.1: SPI Write

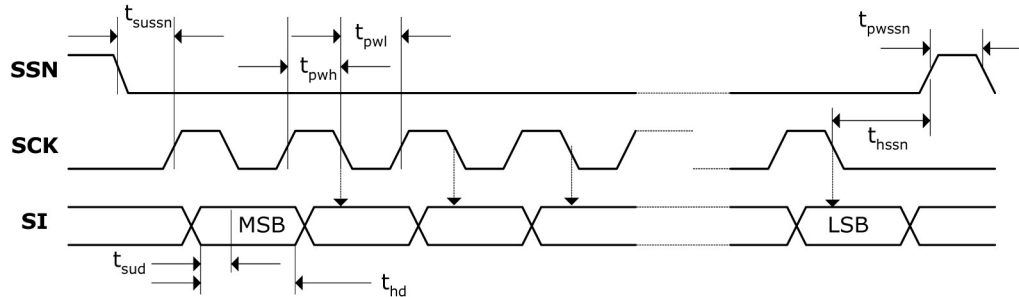
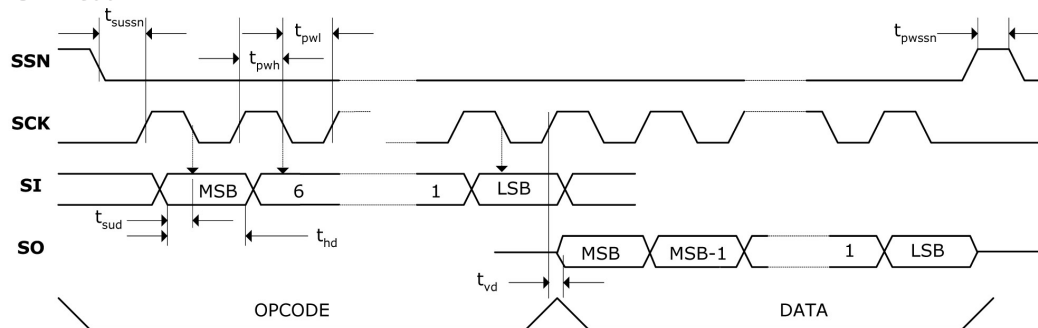
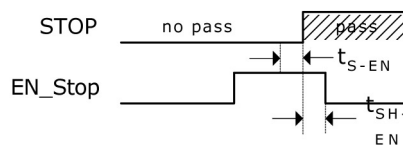

Figure 2.2: SPI Read



### Disable Timings

Figure 2.3:



Spec	Description	Min (ns)	Max (ns)
$t_{S-EN}$	Enable Setup Time	t.b.d. ns	-
$t_{SH-EN}$	Enable Hold Time	t.b.d. ns	-

### Reset Timings

Figure 2.4:

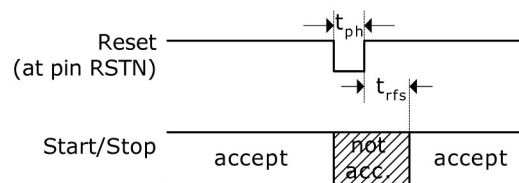

Spec	Description	Min (ns)	Max (ns)
$t_{ph}$	Reset pulse width	t.b.d. ns	-
$t_{rfs}$	Time after rising edge of reset pulse before hits are accepted	t.b.d. $\mu$ s	-

Note: After power-on reset it is necessary to wait minimum 500  $\mu$ s to settle the analog part.

## 2 Characteristics & Specifications

### 2.4 Pin Description

Figure 2-5: TDC-GP22 Pinout

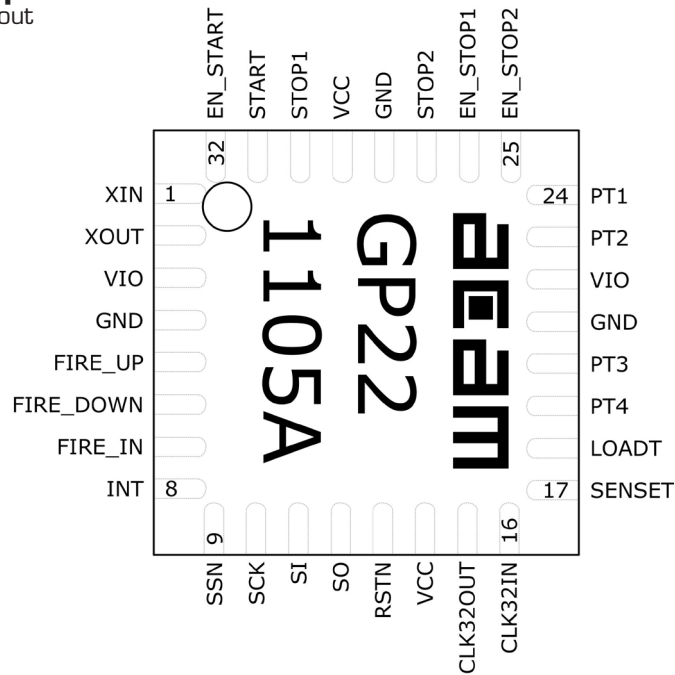

No.	Name	Description	Buffer type	Value	If not used
1	XIN	Oscillator driver in			GND
2	XOUT	Oscillator driver out			
3	VIO	I/O – supply voltage			
4	GND	Ground			
5	FIRE_UP	Fire pulse generator output 1	48 mA		
6	FIRE_DOWN	Fire pulse generator output 2	48 mA		
7	FIRE_IN	Signal input for quasi “Sing Around”			GND
8	INTN	Interrupt flag	4 mA	LOW active	
9	SSN	Slave select		LOW active	
10	SCK	Clock serial interface			
11	SI	Data input serial interface			
12	SO	Data output serial interface	4 mA tristate		
13	RSTN	Reset input		LOW active	
14	VCC	Core supply voltage			
15	CLK32OUT	Output 32 kHz clock generator			n. c.
16	CLK32IN	Input 32 kHz clock generator			GND
17	SENSET	Sense input temperature measurement	Schmitt trigger		GND
18	LOADT	Load output temperature measurement	24 mA		n.c.

## 2 Characteristics & Specifications

No.	Name	Description	Buffer type	Value	If not used
19	PT4*	Port 4 temperature measurement	> 96 mA open drain		
20	PT3*	Port 3 temperature measurement	> 96 mA open drain		
21	GND	Ground			
22	VIO	I/O – supply voltage			
23	PT2*	Port 2 temperature measurement	> 96 mA open drain		
24	PT1*	Port 1 temperature measurement	> 96 mA open drain		
25	EN_STOP2	Enable pin stop input 2		HIGH active	Vio
26	EN_STOP1	Enable pin stop input 1		HIGH active	Vio
27	STOP2	Stop input 2			GND
28	GND	Ground			
29	VCC	Core supply voltage			
30	STOP1	Stop input 1			GND
31	START	Start input			
32	EN_START	Enable pin start input		HIGH active	Vio

\*  $R_{DS(ON)}$  temperature ports: typ.  $1.8 \Omega @ 3.0 V$

### 2.5 Package Drawings

Figure 2-6: QFN-32 package outline, 5 x 5 x 0.9 mm<sup>3</sup>, 0.5 mm lead pitch

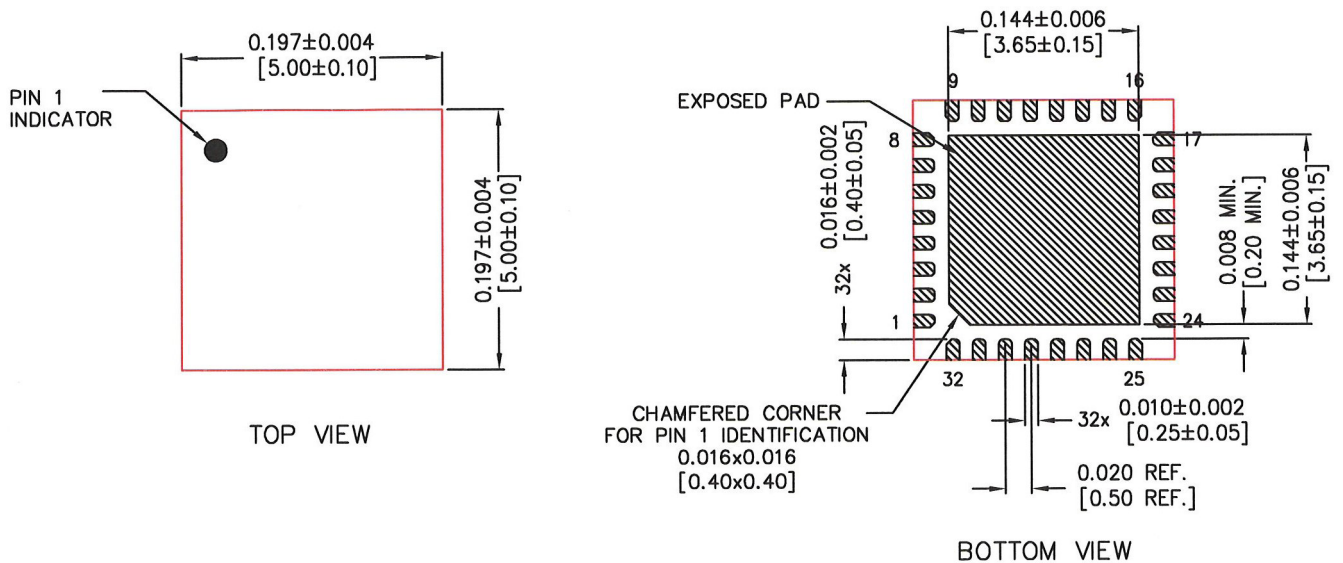

## 2 Characteristics & Specifications

Figure 2-6b: QFN-32 package outline, 5 x 5 x 0.9 mm<sup>3</sup>, 0.5 mm lead pitch

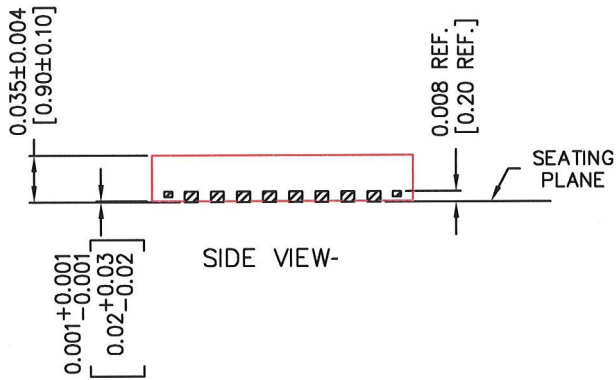

**NOTES:**

1. PACKAGE DIMENSION DOES NOT INCLUDE MOLD FLASH, PROTRUSIONS, BURRS OR METAL SMEARING.
2. COPLANARITY APPLIES TO THE EXPOSED PAD AS WELL AS THE EXPOSED TERMINALS.  
MAXIMUM COPLANARITY SHALL BE 0.003 [0.08].
3. WARPAGE SHALL NOT EXCEED 0.004 [0.10].

Caution: Center pad, 3.65 \* 3.65 mm<sup>2</sup>, is internally connected to GND. No wires other than GND are allowed underneath.

It is not necessary to connect the center pad to GND.

Suitable socket: Plastronics 32QN50S15050D

**Thermal resistance:** Roughly 28 K/W (value just for reference).

**Environmental:** The package is RoHS compliant and does not contain any Pb.

**Moisture Sensitive Level (MSL)**

Based on JEDEC O2O Moisture Sensitivity Level definition the TDC-GP22 is classified as MSL 1.

**Soldering Temperature Profile**

The temperature profile for infrared reflow furnace (in which the temperature is the resin's surface temperature) should be maintained within the range described below.

Figure 2-7: Soldering profile

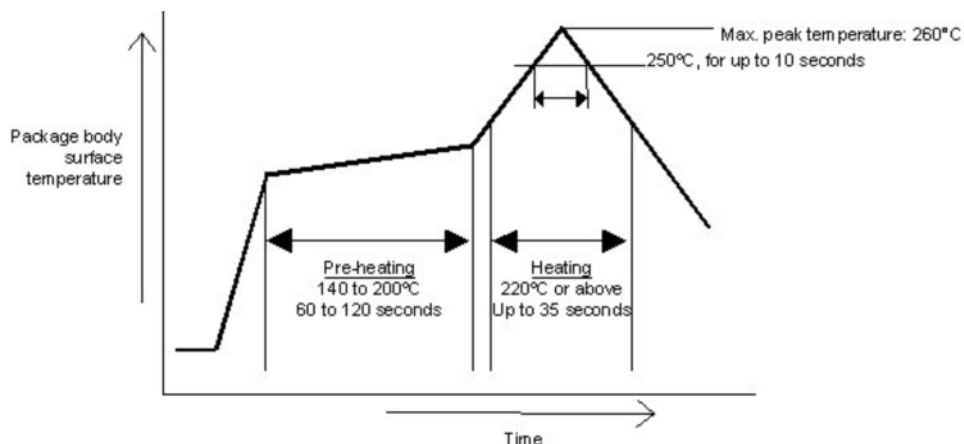



## 2 Characteristics & Specifications

### Maximum temperature

The maximum temperature requirement for the resin surface, given 260°C as the peak temperature of the package body's surface, is that the resin surface temperature must not exceed 250°C for more than 10 seconds. This temperature should be kept as low as possible to reduce the load caused by thermal stress on the package, which is why soldering for short periods only is recommended. In addition to using a suitable temperature profile, we also recommend that you check carefully to confirm good soldering results.

**Date Code:** YYWWA: YY = Year, WW = week, A = Assembly site code

### 2.6 Power Supply

#### Supply voltage

TDC-GP22 is a high end mixed analog/digital device. To reach full performance of the chip a good power supply is mandatory. It should be high capacitive and of low inductance.

The TDC-GP22 provides two pairs of power supply terminals:

Vio - I/O supply voltage

Vcc - Core supply voltage

All ground pins should be connected to a ground plane on the printed circuit board. Vio and Vcc should be provided by a battery or fixed linear voltage regulator. Do not use switched regulators to avoid disturbances caused by the I/O supply.

The measurement quality of a time-to-digital converter depends on a good power supply. The chip sees mainly pulsed current and therefore a sufficient bypassing is mandatory:

Vcc	47 $\mu$ F	(minimum 22 $\mu$ F)
Vio	100 $\mu$ F	(minimum 22 $\mu$ F)

The supply voltage should be provided through analog regulators. We strongly recommend not to use switch mode power supplies.

## 2 Characteristics & Specifications

### Current consumption

The current consumption is the sum from different parties (all data for  $V_{io} = V_{cc} = 3.0V$ ):

$I_{ddq}$	< 5 nA typ. @3.0V, 25°C	Quiescent current, no 32 kHz oscillator running
$I_{32}$	typ. 1.0 $\mu A$	Standby current with active 32 kHz oscillator (GP22 waiting for command).
$I_{hs}$	typ. 130 $\mu A/s$ * (active runtime)	Current into the high speed oscillator at 3.0 V $V_{io}$ .  Example: In ultrasonic flow-meters the high-speed oscillator is on for about 2ms only. The average current consumption is $130 \mu A/s * 2 ms = 0.26 \mu A$
$I_{tmu}$	typ. 4 mA/s * (active measuring time)	Current into the time measuring unit, In measurement range 1 the time measuring unit is active for the start-stop time interval plus the calibration time interval of 2 periods of the reference clock per measurement.  In measurement range 2 the time measuring unit is on for average 4 periods of the reference clock per measurement, two for the time measurement and two for calibration.  Example: With 10 measurements per second in measurement range 2 and a 4 MHz reference clock the time measuring unit is active for only about 10 $\mu s$ .  The average current is $4 mA/s * 10 \mu s = 0.040 \mu A$ .
$I_T$	typ. 2.5 $\mu As$ * measure rate	The current for a full temperature measurement is typ. 2.5 $\mu As$ . In heat-meters the temperature is measured typically once every 30 seconds. The average current is about 0.085 $\mu A$
$I_{ana}$	typ. 0.8 mA	Current consumption of the integrated analog part of TDC-GP22 during a Time-of-flight (ToF) measurement. The analog part is active for a duration of 250 $\mu s$ + ToF.
<b><math>I_{total}</math></b>	<b>2.3 <math>\mu A</math></b>	In a typical ultrasonic heat meter application, the flow is measured twice per second. The temperature is measured every 30 seconds. Typical current consumption of the complete flow and temperature measuring unit, including the analog part, the transducers and PT sensors.

<b>3</b>	<b>Registers &amp; Communication .....</b>	<b>3-2</b>
<b>3.1</b>	<b>Configuration registers .....</b>	<b>3-2</b>
3.1.1	Alphanumeric listing of configuration parameters .....	3-2
3.1.2	List of configuration registers .....	3-4
<b>3.2</b>	<b>Read registers.....</b>	<b>3-14</b>
3.2.1	Result Registers .....	3-14
3.2.2	Status Register .....	3-16
3.2.3	PW1ST Register .....	3-16
<b>3.3</b>	<b>EEPROM.....</b>	<b>3-16</b>
<b>3.4</b>	<b>SPI-interface .....</b>	<b>3-17</b>
3.4.1	Opcode Explanations.....	3-19
3.4.2	SPI Sample.....	3-20

## 3 Registers & Communication

### 3.1 Configuration registers

The TDC-GP22 has 7 configuration registers with 32 bit. The upper 24 bit are used for configuration and are write only. They are used to setup the TDC-GP22 operating mode. The lowest 8 bit can be used e.g. as an ID and can be read back.

For communication test please write to register 1 and read back the highest 8 bit from address 5.

#### Note:

The write registers of TDC-GP22 are fully upwards compatible with TDC-GP21. In addition, the formerly unused bits 30, 31 in register 3 activate new functionality. Especially with bit 30 the First Wave Mode is switched on and the parameter bits DELVAL2 and DELVAL3 in registers 3 and 4 get a new, second meaning.

For proper work of TDC-GP22, a power-up reset via pin or SPI command is necessary after the power-up of the circuit.

#### 3.1.1 Alphanumeric listing of configuration parameters

Table 3-1: Configuration Parameters

Parameter	Register	Bits	Default value	New
ANZ_FAKE	0	15	0	
ANZ_FIRE	6	28-31	2	
	0	8-10		
ANZ_PER_CALRES	0	22,23	0	
ANZ_PORT	0	17	1	
CALIBRATE	0	13	1	
Conf Fire	5	28-31	0	
CURR32K	1	15	1	
CYCLE_TEMP	6	18,19	0	
CYCLE_TOF	6	16,17	0	
DA_KORR	6	25-28	0	
DELREL1	3	8-13	0	x
DELREL2	3	14-19	0	x
DELREL3	3	20-25	0	x
DELVAL1	2	8-23	0	
DELVAL2	3	8-23	0	
DELVAL3	4	8-23	0	
DIS_PHASSHIFT	5	27	0	
DIS_PW	4	16	0	x
DIV_CLKHS	0	20,21	0	
DIV_FIRE	0	24-27	2	

### 3 Registers & Communication

Parameter	Register	Bits	Default value	New
DOUBLE_RES	6	12	0	
EDGE_FW	4	15	0	x
EN_ANALOG	6	31	0	
EN_AUTOCALC_MB2	3	31	0	x
EN_ERR_VAL	3	29	0	
EN_Fast_Init	1	23	0	
EN_FIRST_WAVE	3	30	0	x
EN_INT	2	29-31	1	
	6	21		
EN_STARTNOISE	5	28	0	
FIRE0_DEF	6	14	0	
HIT1	1	24-27	5	
HIT2	1	28-31	5	
Hitin1	1	16-18	0	
Hitin2	1	19-21	0	
HZ60	6	15	0	
IDO	0	0-7	0	
ID1	1	0-7	0	
ID2	2	0-7	0	
ID3	3	0-7	0	
ID4	4	0-7	0	
ID5	5	0-7	0	
ID6	6	0-7	0	
MESSB2	0	11	1	
NEG_START	0	8	1	
NEG_STOP_TEMP	6	30	0	
NEG_STOP1	0	9	1	
NEG_STOP2	0	10	1	
NO_CAL_AUTO	0	12	0	
OFFS	4	8-12	0	x
OFFSRNG1	4	13	0	x
OFFSRNG2	4	14	0	x
PHFIRE	5	8-23	0	
QUAD_RES	6	13	0	
REPEAT_FIRE	5	24-26	0	
RFEDGE1	2	27	0	
RFEDGE2	2	28	0	
SEL_ECLK_TMP	0	14	1	
SEL_START_FIRE	1	14	0	
SEL_TIMO_MB2	3	27,28	3	
SEL_TSTO1	1	8-10	0	

## 3 Registers & Communication

Parameter	Register	Bits	Default value	New
SEL_TSTO2	1	11-13	0	
START_CLKHS	0	18,19	1	
	6	20		
TCYCLE	0	16	0	
TEMP_PORTDIR	6	11	0	
TW2	6	22,23	0	

### 3.1.2 List of configuration registers

Bit number →	15	14	13	12	11	10	9	8	7	6	5	4	3	2	1	0
parameter →	param1						k.d.									
Default value →							1	1	0	0	1	0	1	0	1	0

k.d. = keep default values

#### Register 0 (address 0):

31	30	29	28	27	26	25	24	23	22	21	20	19	18	17	16	15	14	13	12	11	10	9	8	7-0
ANZ_FIRE			DIV_FIRE																IDO					
0	0	1	0	0	0	1	0	0	0	0	0	0	1	1	0	0	1	1	0	1	0	0	0	0

Parameter (Old GP2 name)	Description	Settings
ANZ_FIRE (FIRE#)	Sets number of pulses generated by fire pulse generator. Additional 3 bits are set in register 6.  For values ANZ_FIRE > 15 the phase setting (PHFIRE) can not be used.	0 = off 1 = 1 pulse 2 = 2 pulses ... 127 = 127 pulses
DIV_FIRE	Sets predivider for internal clock signal of fire pulse generator	0 = not permitted 1 = divided by 2 2 = divided by 3 3 = divided by 4 ... 15 = divided by 16
ANZ_PER_CALRES (CALRES#)	Sets number of periods used for calibrating the ceramic resonator	0 = 2 periods = 61.035 µs 1 = 4 periods = 122.07 µs 2 = 8 periods = 244.14 µs 3 = 16 periods = 488.281 µs

### 3 Registers & Communication

DIV_CLKHS (ClkHSDiv)	Sets predivider for CLKHS	0 = divided by 1 1 = divided by 2 2 = divided by 4 3 = divided by 4
START_CLKHS[1:0]	Defines the time interval the chip waits after switching on the oscillator before making a measurement.  Note: The highest bit to adjust START_CLKS is located in register 6, bit 20. This has to be set to 1 for settling times of 2.44 ms and 5.14 ms.	0 = Oscillator off 1 = Oscillator continuously on 2 = settling time 480 $\mu$ s 3 = settling time 1.46 ms 4 = settling time 2.44 ms 5 to 7 = settling time 5.14 ms
ANZ_PORT (PORT#)	Sets number of ports used for temperature measurement	0 = 2 temperature ports (PT1 and PT2) 1 = 4 temperature ports
TCYCLE	Sets cycle time for temperature measurement	0 = 128 $\mu$ s cycle time @ 4 MHz 1 = 512 $\mu$ s cycle time @ 4 MHz (recommended)
ANZ_FAKE (FAKE#)	Number of dummy cycles at the beginning of a temperature measurement	0 = 2 Fake measurements 1 = 7 Fake measurements
SEL_ECLK_TMP (SelClkT)	Select reference signal for internal cycle clock for temperature measurement	0 = use 32.768 kHz as cycle clock 1 = use 128 * CLKHS as period for cycle clock (32 $\mu$ s with 4 MHz high speed clock signal)
CALIBRATE	Enables/disables calibration calculation in the ALU	0 = calibration off (allowed only in mode 1) 1 = calibration on (recommended)
NO_CAL_AUTO (DisAutoCal)	Enables/disables auto-calibration run in the TDC	0 = auto-calibration after measurement 1 = auto-calibration disabled
MESB2 (MRange2)	Switch to measurement range 2	0 = measurement range 1 1 = measurement range 2
NEG_STOP2	Negation stop 2 input	0 = non-inverted input signal – rising edge 1 = inverted input signal – falling edge
NEG_STOP1	Negation stop 1 input	0 = non-inverted input signal – rising edge 1 = inverted input signal – falling edge
NEG_START	Negation start input	0 = non-inverted input signal – rising edge 1 = inverted input signal – falling edge
ID0	Free bits, e.g. to be used as identification or version number	

## 3 Registers & Communication

### Register 1 (address 1):

31	30	29	28	27	26	25	24	23	22	21	20	19	18	17	16	15	14	13	12	11	10	9	8	7-0				
HIT2				HIT1						HITIN2				HITIN1						SEL_TSTO2				SEL_TSTO1				ID1
0	1	0	1	0	1	0	1	0	1	0	0	0	0	0	0	1	0	0	0	0	0	0	0	0				



Parameter	Description	Settings	
HIT2	Defines operator for ALU data post-processing Measure mode 1: HIT1-HIT2 Measure mode 2: HIT2-HIT1	<b>MRange1:</b> 0 = Start 1 = 1. Stop Ch1 2 = 2. Stop Ch1 3 = 3. Stop Ch1 4 = 4. Stop Ch1 5 = no action 6 = Cal1 Ch1 7 = Cal2 Ch1 9 = 1. Stop Ch2 A = 2. Stop Ch2 B = 3. Stop Ch2 C = 4. Stop Ch2	<b>MRange2:</b> 2 = 1. Stop Ch1 3 = 2. Stop Ch1 4 = 3. Stop Ch1
HIT1	Defines operator for ALU data post-processing MRange1: HIT1-HIT2 MRange2: HIT2-HIT1	<b>MRange1:</b> 0 = Start 1 = 1. Stop Ch1 2 = 2. Stop Ch1 3 = 3. Stop Ch1 4 = 4. Stop Ch1 5 = no action 6 = Cal1 Ch1 7 = Cal2 Ch1 9 = 1. Stop Ch2 A = 2. Stop Ch2 B = 3. Stop Ch2 C = 4. Stop Ch2	<b>MRange2:</b> 1 = Start
EN_FAST_INIT	Enables fast init operation	0 = Fast init mode disabled 1 = Fast init mode enabled	



### 3 Registers & Communication

HITIN2	Number of expected hits on channel 2	0 = stop channel 2 disabled 1 = 1 hit 2 = 2 hits 3 = 3 hits 4 = 4 hits 5 to 7 = not permitted
HITIN1	Number of expected hits on channel 1	0 = stop channel 1 disabled 1 = 1 hit 2 = 2 hits 3 = 3 hits 4 = 4 hits 5 to 7 = not permitted
CURR32K	Low current option for 32 kHz oscillator. Basically there is no need to use high current option (1). Low current (0) also guarantees oscillation.	0 = low current (recommended) 1 = high current (GP2 compatibility)
SEL_START_FIRE	Firepulse is used as TDC start. The START input is disabled.	0 = TDC-GP2 behaviour 1 = Use FIRE as Start
SEL_TSTO2	Defines functionality of EN_START pin. Besides the GP2 functionality this pin can act as output for various signals. If SEL_TSTOP2 > 0 then EN_START = HIGH internally.	0 = GP2 functionality, High level enables the START pin. 1 = START_TDC output 2 = STOP1 TDC output 3 = STOP2 TDC output 4 = Stop Temperature measurement output 5 = EN_STOP by DELVAL output 6 = n.c. 7 = 4 kHz (32 kHz/8) clock
SEL_TSTO1	Defines functionality of FIRE_IN pin. Besides the GP2 functionality this pin can act as output for various signals. If SEL_TSTO1 > 1 the FIRE_IN is connected to GND internally.	0 = GP2 functionality, Fire_in input for sing-around 1 = START_TDC output 2 = STOP1 TDC output 3 = STOP2 TDC output 4 = Start Temperature measurement output 5 = TOF=UP, =1 when TOF_UP measurement is active 6 = RUN_HA, =1 when hardmacro is active 7 = 32 kHz clock
ID1	Free bits, e.g. to be used as identification or version number	

## 3 Registers & Communication

### Register 2 (address 2):

31	30	29	28	27	26	25	24	23	22	21	20	19	18	17	16	15	14	13	12	11	10	9	8	7-0	
EN_INT				DELVAL1																				ID2	
0	0	1	0	0	0	0	0	0	0	0	0	0	0	0	0	0	0	0	0	0	0	0	0	0	0

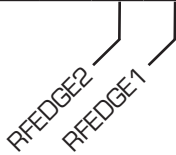

Parameter	Description	Settings
EN_INT	Activates interrupt sources wired by OR. Additional bit in register 6 (see there, too)	Bit 31 = Timeout interrupt enable Bit 30 = End Hits interrupt enable Bit 29 = ALU interrupt enable Reg6, BIT21 = End of EEPROM action
RFEDGE2	Edge sensitivity channel 2	0 = rising or falling edge 1 = rising and falling edge
RFEDGE1	Edge sensitivity channel 1	0 = rising or falling edge 1 = rising and falling edge
DELVAL1	Delay value for internal stop enable unit, hit 1 channel 1. Fixed point number with 14 integer and 5 fractional digits in multiples of Tref	DELVAL1 = 0 to 16383.96875
ID2	Free bits, e.g. to be used as identification or version number	

### Register 3 (address 3) with EN\_FIRST\_WAVE = 0:

31	30	29	28	27	26	25	24	23	22	21	20	19	18	17	16	15	14	13	12	11	10	9	8	7-0
EN_AUTOCAL_MB2				DELVAL2																				ID3
0	0	0	1	1	0	0	1	0	0	0	0	0	0	0	0	0	0	0	0	0	0	0	0	0

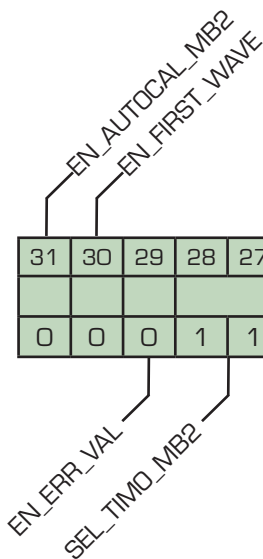

### 3 Registers & Communication

**Register 3 (address 3) with EN\_FIRST\_WAVE = 1:**

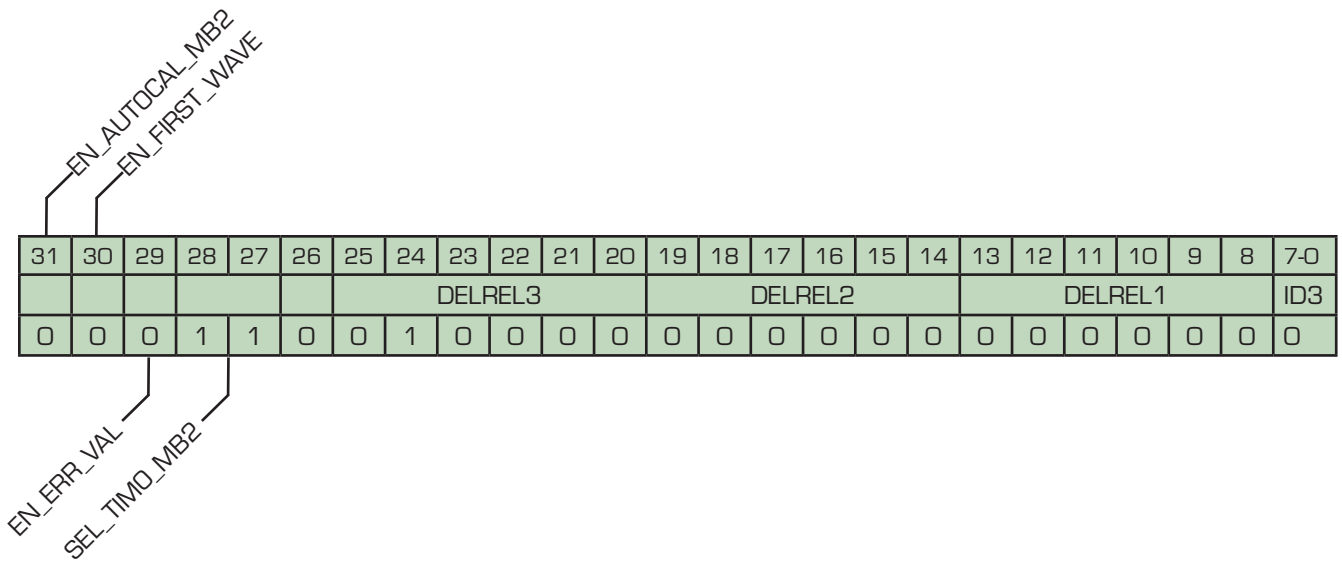

Parameter	Description	Settings
EN_AUTOCALC_MB2	Only in measure range 2: automatic calculation of all enabled hits. The sum of the results is written to read register 4.	0 = disabled 1 = enabled
EN_ERR_VAL	Timeout forces ALU to write 0xFFFFFFFF into the output register	0 = disabled 1 = enabled
EN_FIRST_WAVE	Enables the automatic first hit detection. In case this bit is set registers 3 and 4 get a new meaning	0 = disabled 1 = enabled
SEL_TIMO_MB2	Select predivider for timeout in measurement range 2	0 = 64 μs 1 = 256 μs 2 = 1024 μs 3 = 4096 μs @ 4 MHz ClkHS
DELREL3	Sets the number of the periods after the first hit for the 3rd stop	5 to 63 DELREL3 > DELREL2
DELREL2	Sets the number of the periods after the first hit for the 2nd stop	4 to 63 DELREL2 > DELREL1
DELREL1	Sets the number of the periods after the first hit for the 1st stop	3 to 63
DELVAL2	Delay value for internal stop enable unit, hit 2 channel 1. Fixed point number with 14 integer and 5 fractional digits in multiples of Tref	DELVAL1 = 0 to 16383.96875
ID3	Free bits, e.g. to be used as identification or version number	

## 3 Registers & Communication

**Register 4 (address 4) with EN\_FIRST\_WAVE = 0:**

31	30	29	28	27	26	25	24	23	22	21	20	19	18	17	16	15	14	13	12	11	10	9	8	7-0	
k.d.					DELVAL3																		ID4		
0	0	1	0	0	0	0	0	0	0	0	0	0	0	0	0	0	0	0	0	0	0	0	0	0	0

**Register 4 (address 4) with EN\_FIRST\_WAVE = 1:**

31	30	29	28	27	26	25	24	23	22	21	20	19	18	17	16	15	14	13	12	11	10	9	8	7-0
k.d.																	OFFS					ID4		
0	0	1	0	0	0	0	0	0	0	0	0	0	0	0	0	0	0	0	0	0	0	0	0	0



Parameter	Description	Settings
DELVAL3	Delay value for internal stop enable unit, hit 3 channel 1. Fixed point number with 14 integer and 5 fractional digits in multiples of Tref	DELVAL1 = 0 to 16383.96875
DIS_PW	Disable pulse width measurement	0 = pulse width measurement on 1 = pulse width measurement off
EDGE_FW	Sets the edge sensitivity for the first wave. With a negative offset it is reasonable to trigger on the falling edge of the first wave.	0 = rising edge 1 = falling edge
OFFSRNG2	Additional offset shift by + 20 mV	0 = off 1 = active
OFFSRNG1	Additional offset shift by - 20 mV	0 = off 1 = active
OFFS	2's complement number setting the offset shift in 1 mV steps	0 = 0 mV 1 = +1 mV ... 15 = +15 mV  16 = -16 mV 17 = -15 mV ... 30 = -2 mV 31 = -1 mV
ID4	Free bits, e.g. to be used as identification or version number	

Note: When switching to First Wave Mode make sure that the highest 5 bits have the default values. Especially bit 29 has to be 1.

### 3 Registers & Communication

**Register 5 (address 5):**

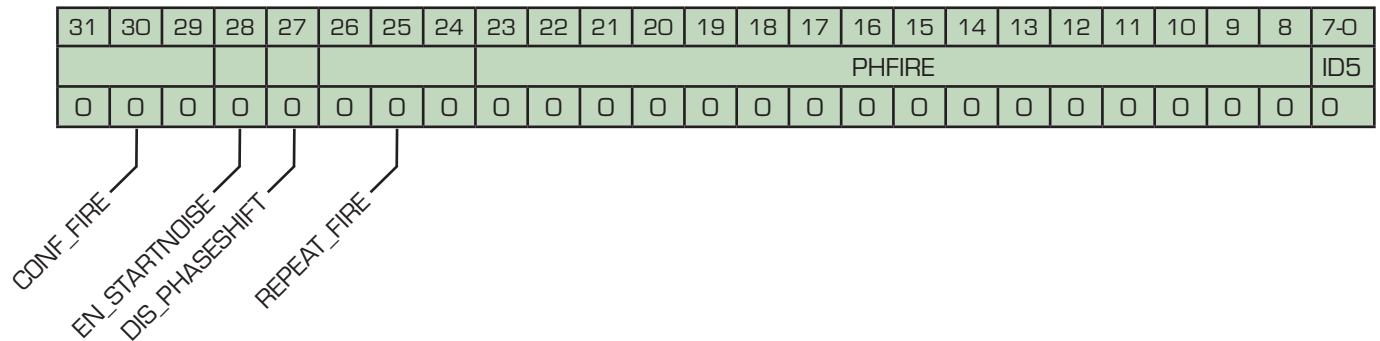

Parameter	Description	Settings
CONF_FIRE	Output configuration for pulse generator 3'b 011 is not allowed	Bit 31 = 1: FIRE_BOTH (inverts FIRE_DOWN) Bit 30 = 1: enable output FIRE_UP Bit 29 = 1: enable output FIRE_DOWN
EN_STARTNOISE	Enables additional noise for start channel	1 = switch on noise unit
DIS_PHASESHIFT (DIS_PHASENOISE)	Phase noise unit. Improves statistjcs and should be enabled if start pulse generation is derived from the GP2 reference clock (e. g. with fire pulse generator).	1 = disables phase noise 0 = enables phase noise unit
REPEAT_FIRE	Number of pulse sequence repetition for "quasi-sing-arround"	0 = no signal repetition 1 = 1 signal repetition 2 = 2 signal repetition ... 7 = 7 signal repetition
PHASE_FIRE	Enables phase reversing for each pulse of a sequence of up to 15 possible pulses	0 = no inversion 1 = inversion
ID5	Free bits, e.g. to be used as identification or version number	

## 3 Registers & Communication

### Register 6 (address 6):

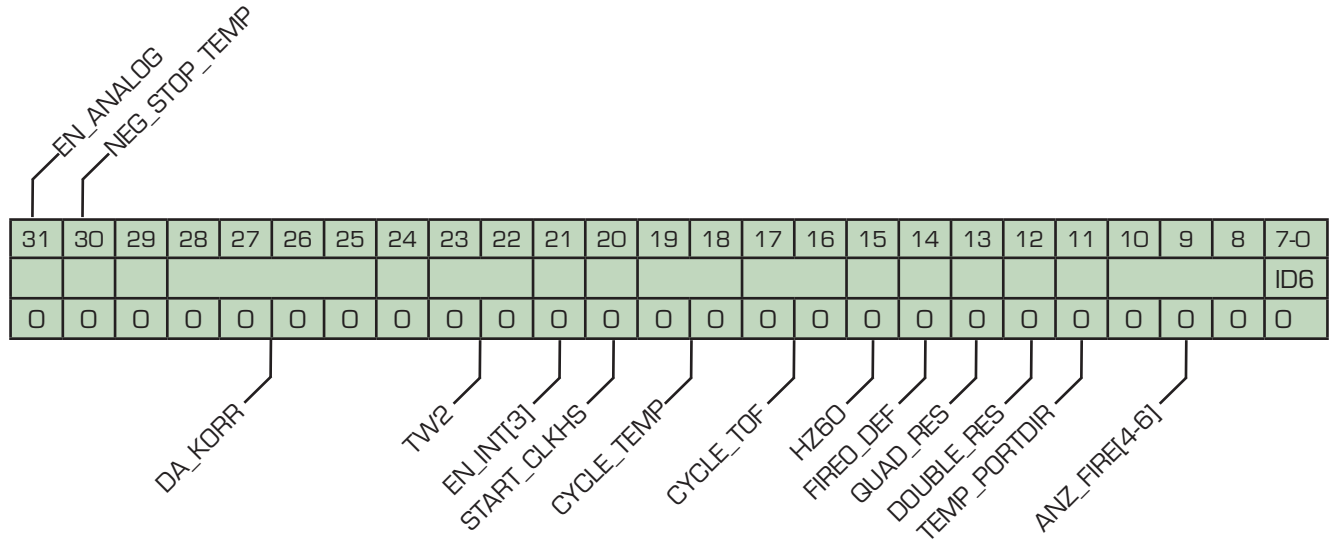

Parameter	Description	Settings
EN_ANALOG	Activates the analog part for the ultrasonic flow measurement is. If active, this section is powered only for the duration of the measurement to save current. STOP1 and STOP2 are analog inputs now and automatically selected by the internal multiplexer.	0 = STOP1 and STOP2 are digital inputs (TDC-GP2 compatibility) 1 = The analog section is used.
NEG_STOP_TEMP	Inverts the SenseT input signal. This is mandatory when the internal comparator is used instead of the external one like in TDC-GP2	0 = external 74HC14 is used (TDC-GP2 compatibility) 1 = internal Schmitt trigger is used
DA_KORR	Sets comparator offset from -8 mV to +7 mV. 2's complement	7 = 7 mV            15 = - 1 mV 6 = 6 mV            14 = - 2 mV ... 1 = 1 mV            9 = - 7 mV 0 = 0 mV            8 = - 8 mV
TW2	Timer to charge up the capacitor of the recommend RC network when the internal analog part is used.	Charge time: 0 = 90 μs 1 = 120 μs 2 = 150 μs 3 = 300 μs, recommended setting
EN_INT	Additional interrupt source. See also register 2 for the lower 3 bits of EN_INT. The various sources are wired by an OR. An EEPROM action, e.g EEPROM_COMPARE, is managed by the TDC-GP21 and especially the EEPROM write may last up to 130ms. Indicating the end will be helpful.	1 = end of EEPROM action

### 3 Registers & Communication

START_CLKHS[2]	Highest bit to set the settling time for the high speed oscillator. The lower bits are set in register 0, bit 20 and 21.	0 = off 1 = continuously on 2 = 480 $\mu$ s delay 3 = 1.46 ms 4 = 2.44 ms 5 to 7 = 5.14 ms
CYCLE_TEMP	Selects timer for triggering the second temperature measurement in multiples of 50/60Hz	0 = 1 1 = 1.5 2 = 2 3 = 2.5
CYCLE_TOF	Selects timer for triggering the second ToF measurement in multiples of 50/60Hz	0 = 1 1 = 1.5 2 = 2 3 = 2.5
HZ60	TDC-GP21 can make complete up and down flow measurement and also two temperature measurements in series. The time interval between 2 measurements is based on 50 or 60 Hz.	0 = 50 Hz base, 20 ms 1 = 60 Hz base, 16.67ms
FIREO_DEF	Specifies the default level of the inactive fire buffer. Example: if FIRE_UP is active then the FIRE_DOWN buffer is connected to the default level. Setting 1 is mandatory when using the integrated analog section.	0 = High-Z (as in GP2) 1 = LOW
QUAD_RES	Option to improve the resolution by factor 4 from 90 ps to 22 ps. Can be used only in measure mode 2.	0 = off (TDC-GP2 mode) 1 = on
DOUBLE_RES	Doubles the resolution from 90 ps to 45 ps. In measure mode 1 this option limits the number of stop inputs to one (Stop1)	0 = off (TDC-GP2 mode) 1 = on
TEMP_PORTDIR	Ports for temperature measurement are measured in the opposite order.	0 = PT1 > PT2 > PT3 > PT4 1 = PT4 > PT3 > PT2 > PT1
ANZ_FIRE[6:4]	Highest 3 bits of the number of fire pulses. See also register 0. If ANZ_FIRE > 15 then PHFIRE is no longer active.	0 = off 1 = 1 pulse 2 = 2 pulses ... 127 = 127 pulses

## 3 Registers & Communication

### 3.2 Read registers

The result and status registers can be read by means of opcode 'hBX. The opcode is followed by 4, 2 or 1 bytes, depending on the address.

The ID register bits in the configuration registers can be read back by means of opcode 'hB7. This opcode is followed by 7 bytes in the order ID0, ID1 ... ID6, each byte with the MSB first.

Table 3-2: Read registers

ADR	Symbol	Bits	Description									
0	RES_0	32	Measurement result 1, fixed-point number with 16 integer and 16 fractional digits $2^{15}$ to $2^{-16}$									
1	RES_1	32	Measurement result 2, fixed-point number with 16 integer and 16 fractional digits									
2	RES_2	32	Measurement result 3, fixed-point number with 16 integer and 16 fractional digits									
3	RES_3	32	Measurement result 4, fixed-point number with 16 integer and 16 fractional digits									
4	STAT	16	15	14	13	12	11	10	9	8 - 6	5 - 3	2 - 0
			EEPROM_eq_CREG	EEPROM_DED	EEPROM_Error	Error short	Error open	Timeout Precounter	Timeout TDC	# of hits Ch2	# of hits Ch1	Pointer result register
5	REG_1	8	Content of highest 8 Bits of write register 1, to be used for testing the communication									
8	PW1ST	8	Pulse width 1st wave compared to measured hits, fixed point with 1 bit integer									

#### 3.2.1 Result Registers

The data structure and the occupancy of the result registers depend on the operation mode and whether calibrated or non-calibrated data are stored. Several cases must be distinguished:

- Only in measure mode 1 negative results are possible.
- In measure mode 2 only positive results are possible, given as unsigned numbers.
- A non-calibrated measure is possible only in measure mode 1.
- In measure mode 1 with calibrated data (ALU) the time intervals that have to be measured can not exceed twice the period of the calibration clock. When measuring bigger time intervals an ALU - overflow will occur and 'hFFFFFFF is written in the appropriate result register.

##### a. Measure mode 1 with calibrated data (Calibrate = 1)

The results are given in multiples of the internal reference clock (= external reference clock divided by



### 3 Registers & Communication

1, 2 or 4 (DIV\_CLKHS)). Calibrated data are 32 bit fixed point numbers with 16 integer bits and 16 fractional bits. Any calibrated result covers therefore 1 result register. The serial output begins with the highest bit ( $2^{15}$ ) and ends with the lowest one ( $2^{-16}$ ). The numbers are available in complements of 2.

$$\text{Time} = \text{RES\_X} * T_{\text{ref}} * 2^{\text{ClkHSDiv}} = \text{RES\_X} * T_{\text{ref}} * N, \text{ with } N = 1, 2 \text{ or } 4$$

$$\text{Time} < 2 * T_{\text{ref}} * 2^{\text{ClkHSDiv}}$$

#### b. Measure mode 1 without calibration (Calibrate = 0)

Non-calibrated data are of the type 'Signed Integer' and are stored as a 16 bit value in the high word of the result registers. The bits of the low word are set to zero. The result is represented as number of LSB and is available in complements of 2.

$$\text{Time} = \text{RES\_X} * \text{LSB} \sim \text{RES\_X} * 90 \text{ ps}$$

#### c. Measure mode 2

In measure mode 2 the TDC-GP22 only supports calibrated measurement. The results are given in multiples of the internal reference clock (= external reference clock divided by 1, 2 or 4 (DIV\_CLKHS)). Calibrated data are 32 bit fixed point numbers with 16 integer bits and 16 fractional bits. Any calibrated result covers therefore 1 result register. The serial output begins with the highest bit ( $2^{15}$ ) and ends with the lowest one ( $2^{-16}$ ). The numbers are available in complements of 2.

$$\text{Time} = \text{RES\_X} * T_{\text{ref}} * 2^{\text{ClkHSDiv}} = \text{RES\_X} * T_{\text{ref}} * N, \text{ with } N = 1, 2 \text{ or } 4$$

#### d. Temperature measurement

Discharge time in the same format as in c., measure mode 2.

The ratio of the discharge times equal the ratio of resistance:

$$R_T = R_{\text{ref}} * \tau_T / \tau_{\text{ref}}$$

### 3 Registers & Communication

#### 3.2.2 Status Register

Table 3-3: Status registers

Bits	Name	Description	Values
2 – 0	Pointer result register	Pointer to the next free result register	
5 – 3	# of hits Ch 1	Number of hits registered on channel 1	
8 – 6	# of hits Ch 2	Number of hits registered on channel 2	
9	Timeout TDC	Indicates an overflow of the TDC unit	1 = overflow
10	Timeout Precounter	Indicates an overflow of the 14 bit precounter in MR 2	1 = overflow
11	Error open	Indicates an open sensor at temperature measurement	1 = open
12	Error short	Indicates a shorted sensor at temperature measurement	1 = short
13	EEPROM_eq_CREG	Indicates whether the content of the configuration registers equals the EEPROM	1 = equal
14	EEPROM_DED	Double error detection. A multiple error has been detected which can not be corrected.	1 = multiple error
15	EEPROM_Error	Single error in EEPROM which has been corrected	1 = error

#### 3.2.3 PW1ST Register

This register holds a 8-bit fixed point number with 1 integer and 7 fractional digits.

PW1ST gives the ratio of the width of the first half wave (at a given offset) compared to the half period of the received signal. See section 4.4 for further details.

Data range: 0 to 1.99219 (with EDGE\_FW = rising edge and negative offset the ratio is > 1).

### 3.3 EEPROM

The TDC-GP22 has a 7x32 bit EEPROM. This EEPROM can be used to store the configuration data together with the ID or version number. Only the following three actions are possible:

- Write configuration register content into the EEPROM
- Transfer the EEPROM content into the configuration registers
- Compare the configuration registers' content with the EEPROM content

Besides the ID it is not possible to read back the EEPROM. This gives customers the possibility to program the chips by themselves and prohibit other to read back the configuration.

For verification it is possible to compare the configuration register may be compare with the EEPROM. Bit EEPROM\_eq\_CREG in the status register indicates whether the content is equal or not.

The EEPROM has an internal error correction (Hamming code). It is possible

### 3 Registers & Communication

- to detect and correct single bit errors,
- to detect multi-bit errors without correction

Errors are indicated in the status register, bits EEPROM\_Error (single bit) and EEPROM\_DED (double error detection).

\*\*\*\*\*With each read access/compare to the EEPROM the error bit is checked. In case a single bit error is detected a refresh cycle is started automatically and the data is restored.

The data retention of the EEPROM is > 10 years @ 85 °C without single or multiple errors. With regular Compare\_EEPROM commands (e.g. once per month) the data retention can be extended unlimited.

#### 3.4 SPI-interface

The serial interface is compatible with the 4-wire SPI standard. It needs the SerialSelectNot (SSN) and can not operated as 3-wire interface.

SSN	- Slave Select
SCK	- SPI Clock
SI	- SPI Data In
SO	- SPI Data Out

The TDC-GP22 does only support the following SPI mode (Motorola specification)\*:

Clock Phase Bit = 1                      Clock Polarity Bit = 0

SCK starts with LOW, data take over is with the falling edge of SCK. The timings are shown in section 2.3. The first rising edge of SCK resets the INTN pin (interrupt).

#### SSN as Reset

The SerialSelectNot (SSN) line is the HIGH-active reset for the serial interface. After SSN is set to LOW different operations can be addressed, not depending on the status of the interface before the reset.

#### Note:

It is mandatory to set the SSN – line to High-state for at least 50 ns between each Read-/Write sequence.

\* There is no common SPI specification, especially for phase& polarity. Some microcontroller may need a different setting, e.g. MSP430 run with Clock Phase = Clock Polarity = 0

### 3 Registers & Communication

#### OPCodes

Table 3-4: Opcodes

Hex	MSB								LSB	Description	Followed by	New
'h8x	1	0	0	0	0	A2	A1	A0	Write into address A	24 bit or 32 bit data		
'hBx	1	0	1	1	0	A2	A1	A0	Read from address A	8, 16 or 32 bit data		
'hB7	1	0	1	1	0	1	1	1	Read ID bit	56 bit ID'S		
'hB8	1	0	1	1	1	0	0	0	Read PW1ST	8bit	x	
'hC0	1	1	0	0	0	0	0	0	Write configuration registers into EEPROM			
'hF0	1	1	1	1	0	0	0	0	Transfer EEPROM content into configuration registers			
'hC5	1	1	0	0	0	1	1	0	Compare configuration registers with EEPROM			
'h70	0	1	1	1	0	0	0	0	Init			
'h50	0	1	0	1	0	0	0	0	Power On Reset			
'h01	0	0	0	0	0	0	0	1	Start_TOF (old name: Start_Cycle)			
'h02	0	0	0	0	0	0	1	0	Start_Temp			
'h03	0	0	0	0	0	0	1	1	Start_Cal_Resonator			
'h04	0	0	0	0	0	1	0	0	Start_Cal_TDC			
'h05	0	0	0	0	0	1	0	1	Start_TOF_Restart			
'h06	0	0	0	0	0	1	1	0	Start_Temp_Restart			

The transfer starts with the MSB and is finished sending the LSB. The transfer is done bitwise. Data transfer can be stopped after each byte, sending a LOW-HIGH-LOW on the SSN line.

Example:

h80 + 3 bytes will write configuration register 0 in the TDC-GP2 compatible mode.

h80 + 4 bytes will write configuration register 0 including ID0 (TDC-GP22 only).

It is not possible to do incremental writing. Each register must be addressed separately.

### 3 Registers & Communication

#### 3.4.1 Opcode Explanations

- 'hCO, 'hFO, 'hC6 all refer to EEPROM operations. Those may last up 130 ms, especially the EEPROM write. Therefore, the EN\_INT bit 3 in register 6 indicates the end of the EEPROM operation. This can be used to adjust microprocessor actions.
- 'hO1, Start\_TOF: triggers a sequence for a single time-of-flight measurement. First, the 4 MHz oscillator is switched on. After the delay set to settle the oscillator (START\_CLKHS), the comparator and the reference voltage are switched on. The receiver capacitor is charged up to  $V_{ref}$  while inactive fire buffer is pulled down to GND. After the delay set to charge up the capacitor (TW2), the fire buffer sends the fire pulses. After the delay set in DELVAL the TDC stop channel is open. At the end of the measurement the analog section and the 4 MHz are switched off and the current consumption drops down to near zero. The interrupt is set, pin INTN = LOW.
- 'hO5, Start\_TOF\_Restart: This new opcode runs the Start\_TOF sequence twice, in up and down direction as it is typical in ultrasonic flow meters. The interrupt is set, pin INTN = LOW, when the time measurement for each direction is finished. So, for one Start\_TOF\_Restart command the microprocessor sees two interrupts and has to read twice. The time interval between the up and down measurement is set by configuration parameter CYCLE\_TOF in multiples of 50 Hz or 60 Hz. The right selection of the delay between the two measurements suppresses 50/60 Hz noise.

CYCLE_TOF	factor	HZ60 = 0(50Hz)	HZ60 = 1(60Hz)
0	1	20 ms	16.67 ms
1	1.5	30 ms	25.00 ms
2	2	40 ms	33.33 ms
3	2.5	50 ms	41.67 ms

- 'hO2, Start\_Temp: triggers a single temperature measurement sequence. It begins with the fake measurements (ANZ\_FAKE) on port PTO. Then it measures ports PTO > PT1 > PT2 > PT4. If TEMP\_PORTDIR is set one then the sequence of ports is inverted, starting with the fake measurements at port PT4.
- 'hO6, Start\_Temp\_Restart: This opcode runs the Start\_Temp sequence twice. The time interval between the up and down measurement is set by configuration parameter CYCLE\_TEMP in multiples of 50 Hz or 60 Hz. The right selection of the delay between the two measurements suppresses 50/60 Hz noise.

## 3 Registers & Communication

CYCLE_TEMP	factor	HZ60 = 0	HZ60 = 1
0	1	20 ms	16.67 ms
1	1.5	30 ms	25.00 ms
2	2	40 ms	33.33 ms
3	2.5	50 ms	41.67 ms

- 'h03, Start\_Cal\_Resonator: Triggers a calibration measurement of the high speed oscillator. The TDC measures a time interval between 61  $\mu$ s and 488  $\mu$ s, specified in ANZ\_PER\_CALRES. The end of the measurement is indicated by the interrupt. The result, in multiples of the high speed clock period, is stored in result register 0. Dividing this by the theoretical value gives the correction factor.
- 'h04, Start\_Cal\_TDC: This command starts a measurement of 2 periods of the reference clock. It is used to update the calibration raw data. Typically, the chip is configured for auto-calibration and this command is not necessary.

### 3.4.2 SPI Sample

Figure 3-1: Sample scope picture for sequence INIT 'h70 and Start\_Cal\_TDC = 'h04

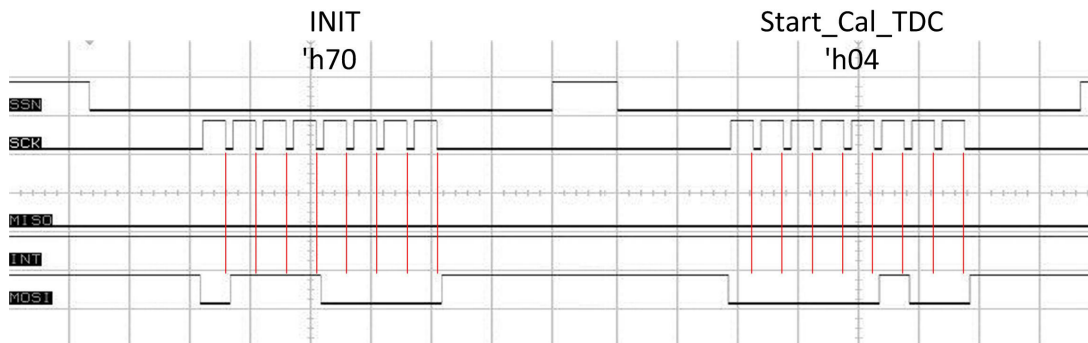

<b>4 Converter Frontend .....</b>	<b>4-2</b>
<b>4.1 TDC - Measure Mode 1.....</b>	<b>4-2</b>
4.1.1 General Description.....	4-2
4.1.2 Measurement Flow.....	4-3
<b>4.2 TDC - Measure Mode 2.....</b>	<b>4-8</b>
4.2.1 General Description.....	4-8
4.2.2 Measurement Flow.....	4-10
4.2.3 Stop Masking .....	4-14
<b>4.3 Analog Input Section .....</b>	<b>4-15</b>
4.3.1 Offset Setting .....	4-16
<b>4.4 First Wave Mode .....</b>	<b>4-17</b>
4.4.1 Configuration.....	4-20
<b>4.5 Temperature Measurement.....</b>	<b>4-21</b>

## 4 Converter Frontend

### 4.1 TDC - Measure Mode 1

#### 4.1.1 General Description

- Measurement range 3.5 ns to 2.4  $\mu$ s (0 to 2.4  $\mu$ s between stop channels)
- 2 stop channels referring to one start channel each of typ. 90 ps resolution
- 1 stop channel referring to one start channel with typ. 45 ps resolution
- 20 ns pulse pair resolution
- 4-fold multihit capability for each stop channel
- Selectable rising/falling edge sensitivity for each channel
- Enable pins for windowing functionality
- The possibility to arbitrarily measure all events against each other
- Typical application: Laser ToF, RF ToF, ATE

Digital TDCs use internal propagation delays of signals through gates to measure time intervals with very high precision. Figure 5 clarifies the principal structure of such an absolute-time TDC. Intelligent circuit structures, redundant circuitry and special methods of layout on the chip make it possible to reconstruct the exact number of gates passed by the signal. The maximum possible resolution strongly depends on the maximum possible gate propagation delay on the chip.

Figure 4.1

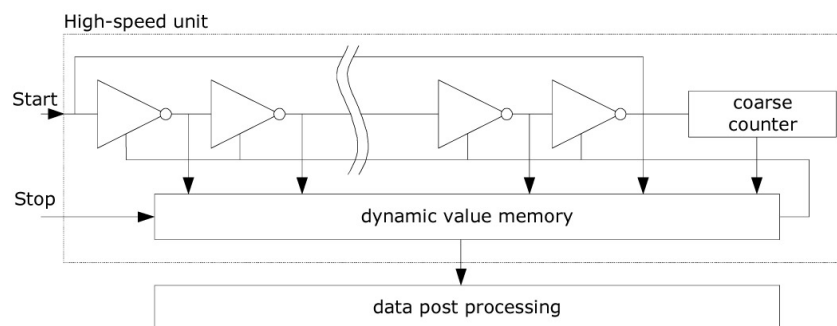

The measuring unit is triggered by a START signal and stopped by a STOP signal. Based on the position of the ring oscillator and the coarse counter the time interval between START and STOP is calculated with a 20 Bit measurement range.

The BIN size (LSB) is typically 90 ps at 3.3 V and 25 °C ambient temperature. The RMS noise is about 60 ps (0.7 LSB). The gate propagation delay times strongly depend on temperature and vol-



## 4 Converter Frontend

tage. Usually this is solved doing a calibration. During such a calibration the TDC measures 1 and 2 periods of the reference clock.

The measurement range is limited by size of the counter:

$$t_{yy} = \text{BIN} \times 26224 \sim 90 \text{ ps} \times 26224 = 2.4 \mu\text{s}$$

	Time (Condition)	Description
t <sub>ph</sub>	2,5 ns (min.)	Minimum pulse width
t <sub>pl</sub>	2,5 ns (min.)	Minimum pulse width
t <sub>ss</sub>	3.5 ns (min.) 2.4 μs (max.)	Start to Stop
t <sub>rr</sub>	20 ns (typ.)	Rising edge to rising edge
t <sub>ff</sub>	20 ns (typ.)	
t <sub>va</sub>	t.b.d. uncalibrated t.b.d. calibrated	Last hit to data valid
t <sub>xx</sub>	No timing limits	
t <sub>yy</sub>	2.4 μs (max)	Max. measuring range = 26224 * LSB

Figure 4.2

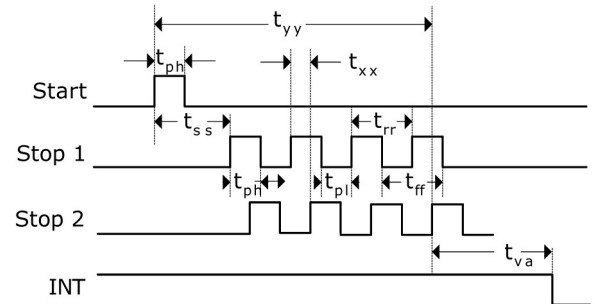

### Input circuitry

Each input separately can be set to be sensitive to rising or falling edge or both edges. This is done in register 0, bits 8 to 10. (NEG\_START, NEG\_STOP1, NEG\_STOP2) and register 2, bit 27&28, RFEDGE<sub>x</sub>.

Furthermore all Start/Stop-inputs support a high active enable pin.

### 4.1.2 Measurement Flow

#### Configuration

At the beginning the TDC-GP22 has to be configured. The main settings for measurement range 1 are:

#### a. Select measure mode 1

Set register 0, bit 11, MESSB2 = 0.

Register 6, bit 12, DOUBLE\_RES = 1 selects double resolution. With this bit set the resolution is typ. 45 ps instead of 90 ps, but only one STOP channel is available.

#### b. Select the reference clock (see also section 5.1)

Register 0, bits 18 & 19 and register 6, bit 20, START\_CLKHS defines the switch-on behavior of

## 4 Converter Frontend

the high-speed clock. If only the 32kHz is used it should be „0“. If only the high-speed clock is used it should be „1“ (continuously on).

Register 0, bits 20 & 21, DIV\_CLKHS sets an additional internal divider for the reference clock (1,2 or 4). This is important for calibrated measurements in measurement range 1 because the ALU works correctly only if  $2 * T_{ref}(intern)$  is bigger than the maximum time interval to be measured. Otherwise the ALU output is 'hFFFFFFF'.

Make also sure that  $2 * T_{ref}(intern) < 2.4 \mu s$  to avoid a timeout during calibration.

Figure 4.3

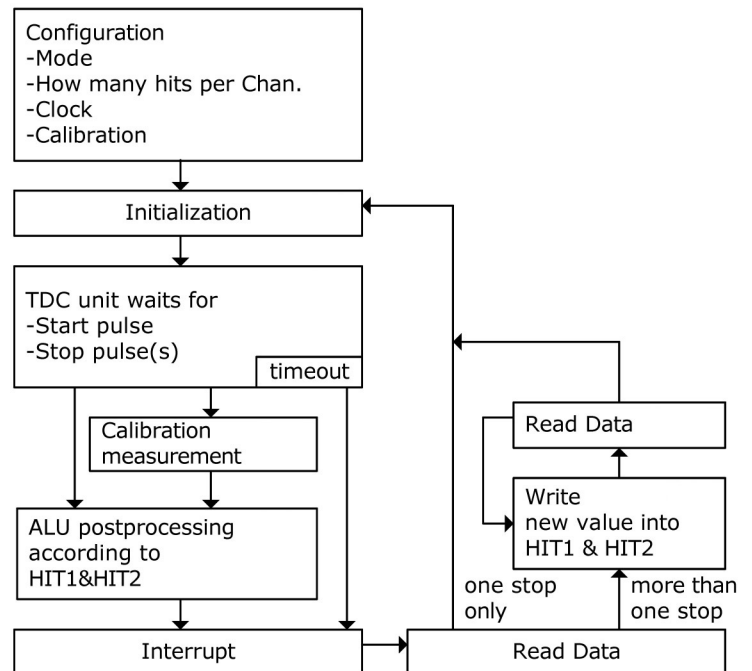

### c. Set the number of expected hits

In register 1, bits 16 to 18 and 19 to 21, HITIN1 and HITIN2 the user has to define the number of hits the TDC-GP22 has to wait for. A maximum of 4 on each channel is possible. The TDC-GP22 measures until the set number of hits is registered or a timeout occurs.

### d. Select calibration

As the BIN size varies with temperature and voltage the TDC-GP22 ALU can internally calibrate the results. This option is switched on by setting register 0, bit13, CALIBRATE = „1“. It is recommended to do this.

For the calibration the TDC measures 1 and 2 cycles of the reference clock. The two data are stored as Cal1 and Cal2.

There are two ways to update the calibration data Cal1 and Cal2:

- Separate calibration by sending opcode Start\_Cal\_TDC via the SPI interface
- Automatic update by setting register 0, bit 12, NO\_CAL\_Auto = „0“. In most applications this will be the preferred setting.

### e. Define ALU data processing

While the TDC unit can measure up to 4 hits on each channel the user is free in his definition what

## 4 Converter Frontend

the ALU shall calculate. The settings are done in register 1, bits 16 to 19 and 20 to 23, HIT1 and HIT2. Both parameters can be set to:

0 = Start

1 = 1. Stop Ch1      9 = 1. Stop Ch2

2 = 2. Stop Ch1      A = 2. Stop Ch2

3 = 3. Stop Ch1      B = 3. Stop Ch2

4 = 4. Stop Ch1      C = 4. Stop Ch2

6 = Cal1 Ch1

7 = Cal2 Ch1

Examples:  
 Reg1 = 0x01xxxx - 1st Stop Ch1-Start  
 Reg1 = 0x2Bxxxx - 3rd Stop Ch2-2nd Stop Ch1  
 Reg1 = 0x06xxxx - Cal1

The ALU calculates Hit1 - Hit2.

In case calibration is active the ALU does the full calibration calculation (except when reading the calibration values. In this case the ALU writes the Cal1/Cal2 raw data to the output register).

$$RES\_X = \frac{(HIT1 - HIT2)}{Cal2 - Cal1}$$

Cal2 - Cal1 = gradient

$$Time = RES\_X \times T_{ref} \times 2^{ClkHSDiv} = RES\_X \times T_{ref} \times N \quad N = 1, 2 \text{ or } 4.$$

Figure 4.4

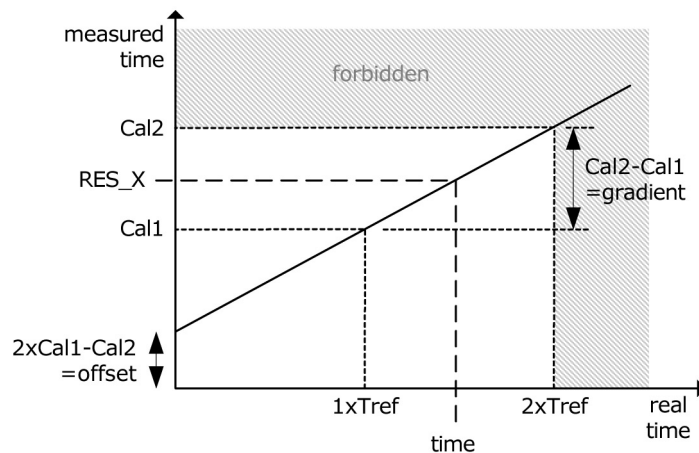

### f. Select input sensitivity

In register 2, bits 27 & 28, RFEDGE1 and RFEDGE2, the user can select whether the stop inputs are sensitive to either rising or falling edges (RFEDGE = „0“) or to both rising and falling edges (RFEDGE = „1“).

## 4 Converter Frontend

In register 0, bits 8 to 10 the user can add an internal inverter to each input, Start, Stop1 and Stop2. With RFEDGE = „0“ this is the same as rising edge (NEG\_X = „0“) or falling edge (NEG\_X = „1“).

### g. Interrupt behavior

The interrupt pin 8, INT can have different sources. They are selected in register 2, bits 29 to 31, EN\_INT and register 6, bit 21.

Reg 2 bit 29 = 1	ALU ready
Reg 2 bit 30 = 1	The set number of hits is there
Reg 2 bit 31 = 1	Timeout of the TDC unit
Reg 6 bit 21 = 1	End of EEPROM action

The different options are wired by OR to enable more than one source. The first rising edge of SCK resets the INTN pin (interrupt).

After the configuration the user has to initialize the TDC-GP22 by sending opcode “Init” so that the TDC accepts Start and Stop hits.

### Measurement

After an initialization the TDC unit will start with the first pulse on the Start input. It will run until:

- the set number of hits has been seen (maximum 4 on both stop channels in mode 1)
- or until a timeout occurs at the end of the measurement range (at about 2.4  $\mu$ s in mode 1).

The time measurement raw data are internally stored. The number of hits can be seen from the status register, bits 3 to 8. In case calibration is active the TDC now measures one and two periods of the internal reference clock (Tref \* 1, 2 or 4). The calibration raw data Cal1 and Cal2 are also internally stored.

Figure 4.5

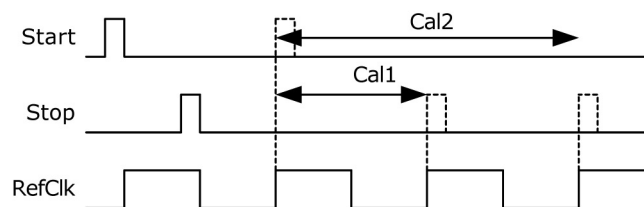

## 4 Converter Frontend

### Data Processing

At the end of the measurement the ALU starts to process the data according to the HIT1, HIT2 settings and transfers the result to the output register. In case calibration is off the ALU transfers the 16 bit raw data to the output register. With calibration the ALU calculates according to 3.1.1.d and transfers the 32 bit fixed point number to the output register.

The ALU can be switched off configuring HIT1=HIT2=5.

The time it takes the ALU depends on whether calibration is on or not and the supply voltage.

Table 4.1: ALU timings

	un-calibrated	calibrated
3.3 V	t. b. d.	t. b. d.
2.5 V	t. b. d.	t. b. d.

As soon as the data is available from the output register the interrupt flag is set (assumed that the ALU interrupt is enabled, see reg 2, EN\_INT). Further the load pointer of the output register is increased by 1 and points to the next free memory. The actual position of the load pointer can be seen in the status register, Bits 0 to 2.

### Reading Data

Now the user can read the data sending the opcode 10110ADR. With the next 16 clock cycles (un-calibrated data) or 32 clock cycles (calibrated data) the TDC-GP22 will send the result, beginning with the most significant Bit (MSB). The first rising edge of SCK resets the INTN pin (interrupt).

#### a. Un-calibrated data format:

16 Bit Signed integer in complements of 2.  
 1BIN = uncalibrated gate delay is about 90 ps at 3.3 V and 25 °C.

$$\text{Time} = \text{RES\_X} \times 90 \text{ ps}$$

#### b. Calibrated data format:

32 Bit fixed-point number in complements of 2. Given in multiples of the reference clock.

$$\text{Time} = \text{RES\_X} * T_{\text{ref}} * N, \quad N = 1, 2 \text{ or } 4$$

The measured time interval may not exceed ,

```

Example:
configuration
...
write reg1='h014400    4 hits on channel 1,
calculate 1st Stop -Start
...
Initialize
...
while(Check interrupt flag)
write reg1='h024400    calculate 2nd -Start
wait(4.6µs)
write reg1='h034400    calculate 3rd-Start
wait(4.6µs)
write reg1='h044400    calculate 4th-Start
wait(4.6µs)

Now all Hit data are available from registers 0 to 3. The load
pointer value is 4.
    
```

## 4 Converter Frontend

otherwise the ALU will go into overflow and will write the data 'hFFFFFFF to the output register.

The configuration of the ALU allows only one hit calculation at the time. In case more than one hit has been measured it is necessary to write new commands to HIT1/HIT2 to instruct the ALU for calculating the other hits. After writing to HIT1/HIT2 it is necessary to wait for minimum t.b.d.  $\mu$ s (calibrated data) or t.b.d. ns (un-calibrated data) before reading or writing again to HIT1/HIT2.

At the end the TDC-GP22 has to be initialized again to be ready for the next measurement. This is done by sending the opcode „Init“ so that the TDC accepts new Start and Stop hits.

### 4.2 TDC - Measure Mode 2

#### 4.2.1 General Description

- 1 stop channels referring to one start channel
- Typical 22 ps / 45 ps / 90 ps resolution
- Measurement range 2 x Tref to 4 ms @ 4MHz
- 2 x Tref pulse pair resolution
- 3-fold multihit capability, full-automated calculation
- Selectable rising/falling edge sensitivity
- Integrated programmable windowing for each single stop with 10 ns precision
- Typical application: Ultrasonic flow & heat meter

Digital TDCs use internal propagation delays of signals through gates to measure time intervals with very high precision (see also measurement range 1, section 4). In measurement range 2 the maximum time interval is extended using a pre-divider. The resolution in LSB remains unchanged by that. In this mode the high-speed unit of the TDC does not measure the whole time interval but only time intervals from START and STOP to the next rising edge of the reference clock (fine-counts). In between the fine-counts the TDC counts the number of periods of the reference clock (coarse-count).

Figure 4.6

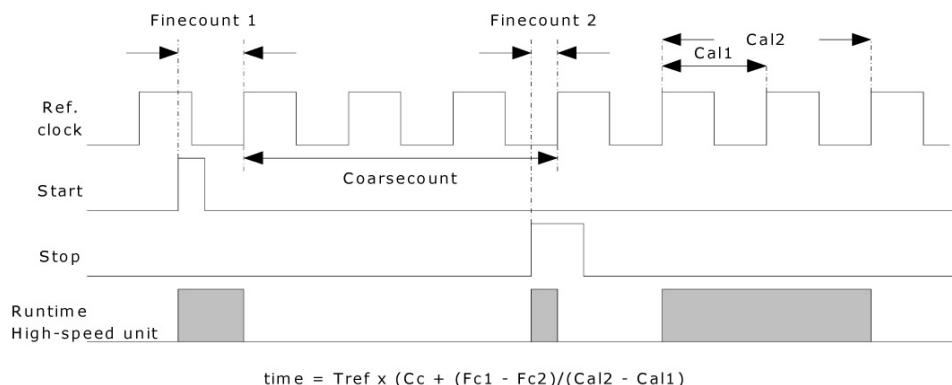

## 4 Converter Frontend

The BIN size (LSB) is typically 90 ps at 3.3 V and 25 °C ambient temperature. The RMS Noise is approx. 60 ps (0.7 LSB). The gate propagation delay times strongly depend on temperature and voltage. In measuring range 2 the result is the sum of different fine and coarse-count results. Therefore it is necessary in measuring range 2 to make a calibration. During a calibration the TDC measures 1 and 2 periods of the reference clock.

**A calibrated result does not depend on temperature or supply voltage.**

The measurement range is limited by size of the coarse counter:

$$t_{yy} = T_{ref} \times 2^{14} = 4.1 \text{ ms @ 4MHz}$$

The time interval between START and STOP is calculated with a 26 bit measurement range.

Figure 4.7

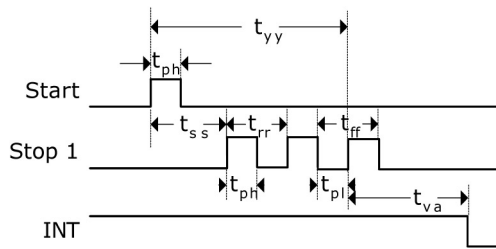

	Time (Condition)	Description
tph	2,5 ns (min.)	Minimum pulse width
tpl	2,5 ns (min.)	Minimum pulse width
tss	2 * Tref	Start to Stop @ Dis_PhaseNoise=1
trr	2 * Tref	Rising edge to rising edge
tff	2 * Tref	Falling edge to falling edge
tva	4.6 μs (max.)	ALU start to data valid
tyy	4 ms (max)	Max. measuring range

### Input circuitry

Each input separately can be set to be sensitive to rising or falling edge. This is done in register 0, Bits 0 to 2. (NEG\_START, NEG\_STOP1).

Further all Start/Stop-inputs support a high active enable pin.

### Note:

In case the Start-Stop interval is less than the lower limit  $t_{zz}$  the TDC will ignore more and more events the smaller it is. In no case there will be wrong results.

## 4 Converter Frontend

### 4.2.2 Measurement Flow

Figure 4.8

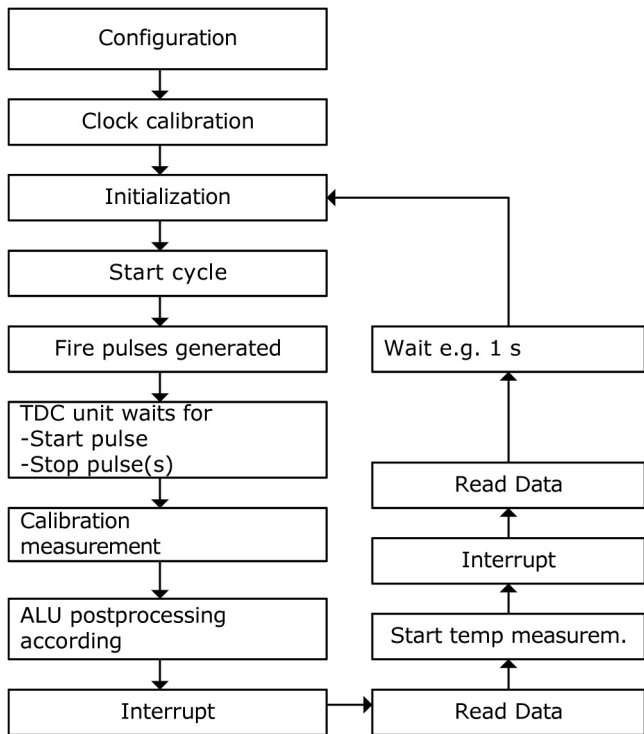

#### Configuration

At the beginning the TDC-GP22 has to be configured. The main settings for measurement range 2 are:

##### a. Select measurement range2

setting register 0, Bit11, MRange2 = 1.

##### b. Select the reference clock

(see also section 5.1)

In measurement range 2 the TDC-GP22 needs the high-speed clock for the time measurement. In case of low-power applications this clock can be switched off in between measurements. The a 32.768 kHz clock is necessary for the timing control during the oscillator power-on.

Register 0, Bits 18&19, START\_CLKHS defines the switch-on behavior of the high-speed clock. If only the high-speed clock is used this is be set to „1“(continuously on). In case both oscillators are used for current saving reasons this should be set to „2“ for ceramic oscillators and to „3“ for quartz oscillators“.

Register 0, Bits 20&21, ClkHSDiv sets an additional internal divider for the reference clock (1,2 or 4). The choice has an influence on the minimum time interval

$$t_{\min} = 2 * T_{\text{ref}} * 2^{\text{ClkHSDiv}}$$

and the maximum time interval

$$t_{\max} = 2^{14} * T_{\text{ref}} * 2^{\text{ClkHSDiv}}$$

Further, it is necessary that

$$2 * T_{\text{ref}} * 2^{\text{ClkHSDiv}} < 2.4 \mu\text{s}.$$

Otherwise the ALU will go into an overflow during calibration and write 'hFFFFFFF' as output data.



## 4 Converter Frontend

### Please note:

The resulting clock after the predivider has to be in the allowed range of 2 MHz to 8 Mhz in single and double resolution and from 2 MHz .... 6 MHz in quad resolution.

### c. Set the number of expected hits

In register 0, Bits 16 to 18, HITIN1 the user has to define the number of hits the TDC-GP22 has to wait for. A maximum of 3 on channel 1 is possible. The number HITIN1 always has to be higher by 1 than the number of expected hits. The reason is that the Start is also counted as a hit. The TDC-GP22 measures until the set number of hits is registered or a timeout occurs. register 0, Bits 11 to 13, HITIN2 have to be set to „0“.

#### Example:

2 stop pulses are expected:

HITIN1 = 3, HITIN2 = 0

### d. Select calibration

The calibration is switched on by setting register 0, Bit13, Calibrate = „1“. It is mandatory to do this. For the calibration the TDC measures 1 and 2 cycles of the reference clock. The two data are stored as Cal1 and Cal2.

There are two ways to update the calibration data Cal1 and Cal2:

- Separate calibration by sending opcode Start\_Cal\_TDC via the SPI interface
- Automatic update by setting register 0, Bit 12, NO\_AUTO\_CAL = „0“. In most applications this will be the preferred setting.

### e. Define ALU data processing

With EN\_AUTOCALC\_MB2 = 1 the TDC-GP22 calculates all set hits automatically. In addition, the sum of the results is calculated, too, and written into read register RES\_3. This simplifies the communication compared to TDC-GP21 as it is no longer necessary to re-write register 1.

With EN\_AUTOCALC\_MB2 disabled the ALU calculates only one hit at once. The settings are done in register 1, Bits 24 to 27 and 28 to 31, HIT1 and HIT2. The Start pulse is internally handled like a Stop pulse because of the special measuring method in measurement range 2.

Reg1 = 'h21xxx = Calculate 1st Stop Ch1-Start

Reg1 = 'h31xxx = Calculate 2nd Stop Ch1-Start

Reg1 = 'h41xxx = Calculate 3rd Stop Ch1-Start

## 4 Converter Frontend

The ALU calculates the time interval as:

$$\text{RES\_X} = \text{CoarseCount} + \frac{(\text{HIT1} - \text{HIT2})}{\text{Cal2} - \text{Cal1}}$$

$$\text{Time} = \text{RES\_X} * T_{\text{ref}} * 2^{\text{ClkHSDiv}}$$

### f. Select input sensitivity

In register 2, Bits 27 & 28, RFEDGE1 and RFEDGE2, the user can select whether the stop inputs are sensitive to either rising or falling edges (RFEDGE = „0“) or to both rising and falling edges (RFEDGE = „1“). In register 0, Bits 8 to 10 the user can add an internal inverter to each input, Start, Stop1 and Stop2. With RFEDGE = „0“ this is the same as rising edge (NEG\_X = „0“) or falling edge (NEG\_X = „1“).

### g. Interrupt behavior

The INT pin can have various sources, to be selected in register 2, Bits 21 to 23, EN\_INT, , and register 6 Bit 21 EN\_INT.

EN_INT =	no bits set	no Interrupt source
	reg2 Bit29	ALU ready
	reg2 Bit30	The set number of hits is there
	reg2 Bit31	Timeout of the TDC unit
	reg6 Bit21	EEPROM action has finished

The different options are wired by OR. The first rising edge of SCK resets the INTN pin (interrupt).

After the configuration the user has to initialize the TDC-GP22 by sending opcode „Init“ so that the TDC accepts Start and Stop hits.

### Measurement

After an initialization the TDC unit will start with the first pulse on the Start input. It will run until:

- the set number of hits has been seen (maximum 3 on channel 1 in measurement range 2)
- or until a timeout occurs. The timeout can be programmed in multiples of the reference clock setting Reg 3, Bits 27&28, SEL\_TIMO\_MR2. At 4 MHz the values are:

## 4 Converter Frontend

SEL\_TIMO\_MR2 (@ 4 MHz, ClkHSDiv = 0)

= 0	= 64 $\mu$ s
= 1	= 256 $\mu$ s
= 2	= 1024 $\mu$ s
= 3	= 4096 $\mu$ s

At the end of the time measurement the TDC measures 2 periods of the reference clock for calibration.

### Data processing

At the end of the measurement the ALU starts to process the data according to the HIT1, HIT2 settings and transfers the result to the output register. The ALU calculates according to 4.2.2.e and transfers the 32 bit fixed point number to the output register.

The time it takes the ALU depends on the supply voltage and the number of hits to be calculated:

Table 4-2: ALU timings

	1 Hit	2 Hits	3 Hits
3.3 V	t.b.d $\mu$ s		
2.5 V	t.b.d. $\mu$ s		

As soon as the data is available from the output register the interrupt flag is set (assumed that the ALU interrupt is enabled, see reg 2, EN\_INT). Further the load pointer of the output register is increased by 1 and points to the next free memory. The actual position of the load pointer can be seen in the status register, Bits 0 to 2.

### Reading Data

Now the user can read the data sending the opcode 10110ADR. With the next 32 cycles (calibrated data) the TDC-GP22 will send the result, beginning with the main significant bit (MSB).

The 32 bit fixed-point numbers in complements of 2 represent the time interval in multiples of the reference clock.

$$\text{Time} = \text{RES\_X} * T_{\text{ref}} * 2^{\text{ClkHSDiv}}$$

## 4 Converter Frontend

Now all hit data are available from registers 0 to 2. The load pointer value is 3.

At the end the TDC-GP22 has to be initialized again to be ready for the next measurement. This is done by sending the opcode „Init“ so that the TDC accepts new Start and Stop hits.

The first rising edge of SCK resets the INTN pin (interrupt).

### 4.2.3 Stop Masking

The TDC-GP22 can set time-based masking windows for each of the 3 hits on Stop1 input when no hits are accepted. The masking refers to the start event and has an accuracy of less than 10 ns.

The internal enable unit is connected to the external enable pin by a logical AND. The external enable pin must be set to “1” to use the internal masking unit. The configuration settings are made in registers 2 to 4, DELVAL1, DELVAL2 and DELVAL3:

- DELVAL1 ... DELVAL3 are fixed point numbers with 14 bit integer and 5 bit fractional digits, in multiples of the internal reference clock

$$\text{Delay}_{\min} = \text{DELVALX} / 2^5 * T_{\text{ref}} * 2^{\text{ClkHSDiv}}$$

- The minimum mask size is 3 clock cycles
- The mask values must have an ascending order. Each mask value must be 3 clock cycles bigger than the previous value

It is mandatory that if not all registers are used the mask values that are not required are set to “0”. When all DELVAL registers are set to 0, the complete unit is disabled.

Example:

4 Mhz reference, ClkHSDiv = 1

DELVAL1 = 'h3200	1st Stop not accepted before 200 µs after Start (128000/32 * 250ns * 2 <sup>1</sup> = 200 µs)
DELVAL2 = 'h3300	2nd Stop not accepted before 204 µs after Start (13056/32 * 250ns * 2 <sup>1</sup> = 204 µs)
DELVAL3 = 'h3400	3rd Stop not accepted before 208 µs after Start (13312/32 * 250ns * 2 <sup>1</sup> = 208 µs)

## 4 Converter Frontend

### 4.3 Analog Input Section

Compared to TDC-GP2, the TDC-GP22 got an additional analog input section which can be used alternatively to the pure digital inputs. Especially the design of ultrasonic flow and heat meters is greatly simplified by this new option. The external circuit of the ultrasonic part is reduced to just two resistors and capacitors additional to the piezo transducers.

The ultrasonic signals will be packages of 50 to 200 sinusoidal oscillations with a several 100 mV amplitude. The signals are coupled to the inputs by means of a highpass filter as the comparator can not handle GND as threshold. The threshold of the comparator is set to  $1/3 V_{CC}$ . An analog multiplexer selects the input according to the active measurement direction. The comparator is chopper stabilized to guarantee a low offset voltage in the range of  $< 2$  mV. This is mandatory for a good measurement quality. The input offset voltage of the comparator is frequently corrected by an internal chopper circuit. If temperature or supply voltage changes over time, the offset voltage is automatically adapted and hold at  $< 2$  mV.

All elements are controlled by the TDC-GP22 control unit. They are powered only during the measurement to keep down the power consumption.

A measurement sequence, triggered by command `Start_TOF_Restart` looks like the following procedure, starting with the up flow measurement:

- The 4 MHz oscillator is switched on. The chips waits for the programmed delay to give enough time for the oscillator to reach the full amplitude.
- The comparator, the reference voltage and the analog switches get powered.
- The capacitor of the transmitting path (STOP1) is connected to GND.
- The fire down buffer (FIRE\_DOWN) is connected to GND.
- The capacitor of the receiving path (STOP2) is charged up to  $V_{ref}$ . The TDC waits the delay set in TW2.
- The analog switch selects STOP2 input as input to the comparator.
- FIRE\_UP is selected as TDC START signal.
- The set number of pulses is sent through the fire up buffer, pin FIRE\_UP.
- The analog signal at STOP2 passes the comparator converted to a digital signal that is connected to the STOP input of the TDC unit.
- When the delay of the stop masking unit (DELVAL) expired the TDC is ready to measure. It can measure up to 3 stops.

## 4 Converter Frontend

Figure 4.9:

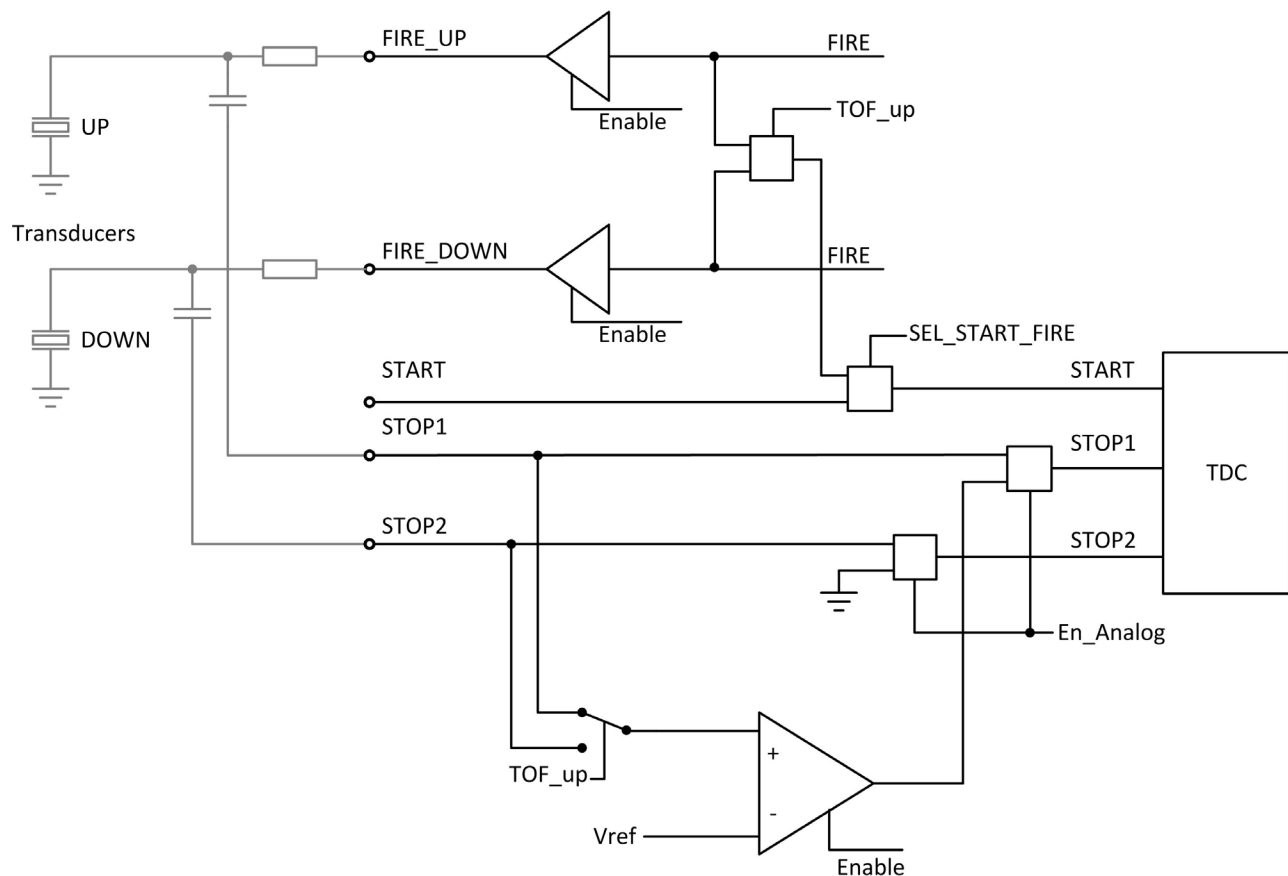

- At the end of the measurement the control unit switches off the comparator, the reference the analog switches and the 4 MHz. The current is reduced to close zero. The interrupt flag is set.
- The control unit waits a period, given in multiples of 50Hz/60Hz. During this this the processor has to read the results.
- After the delay the same procedure is started but in the opposite direction.

### 4.3.1 Offset Setting

The offset of the comparator can be set in steps of 1 mV from -8mV to +7 mV by means of parameter DA\_korrt, bits 25 to 28 in register 6. DA\_korrt is set as 2's complement.

Additionally, with First Wave Mode an additional offset of  $\pm 35$  mV can be set for the first wave detection. See section 4.4 for details.

## 4 Converter Frontend

### 4.4 First Wave Mode

The major improvement of TDC-GP22 is the implementation of the First Wave Mode. It is based on measure mode 2 with the analog section being used. As a new feature, the offset is controlled automatically to detect the first wave safely and to refer the final ToF measurement relative to the first wave. Additionally, the width of the first half wave is compared to the half wave of the first ToF measurement. The ratio can be used as indicator for the signal strength. Thanks to the offset noise is suppressed and a time out indicates no water in the tube. The following list summarizes the new options:

- Save first wave detection, allows high dynamic applications like water meters
- Higher dynamics allow use of 2 MHz or 4 MHz transducers
- Even reverse flow can be handled (very helpful e.g. with water meters)
- Pulse width measurement, allows to analyse the strength of the receive signal and to track the trigger level or to send an alarm.
- Offset for noise suppression, allows to indicate an empty tube.

Figure 4-10 illustrates the importance of save first hit detection in flow meters with high dynamic range like water meters. With a fixed stop masking (fixed DELVAL values) it is not possible to recognize if the time-of-flight changes more than the period of the sound signal. There are several reasons that the change in ToF is more than a period. An important one is the influence of temperature which changes the speed of ultrasound. For slow systems like heat meters this might be corrected by intelligent software. But for high dynamic systems like water meters with flow also in the opposite direction this method will no longer be appropriate.

The trend towards higher transducer frequencies like 2 MHz and 4 MHz is another reason for having a system that can

Figure 4-10: Typical error by high fluid dynamics

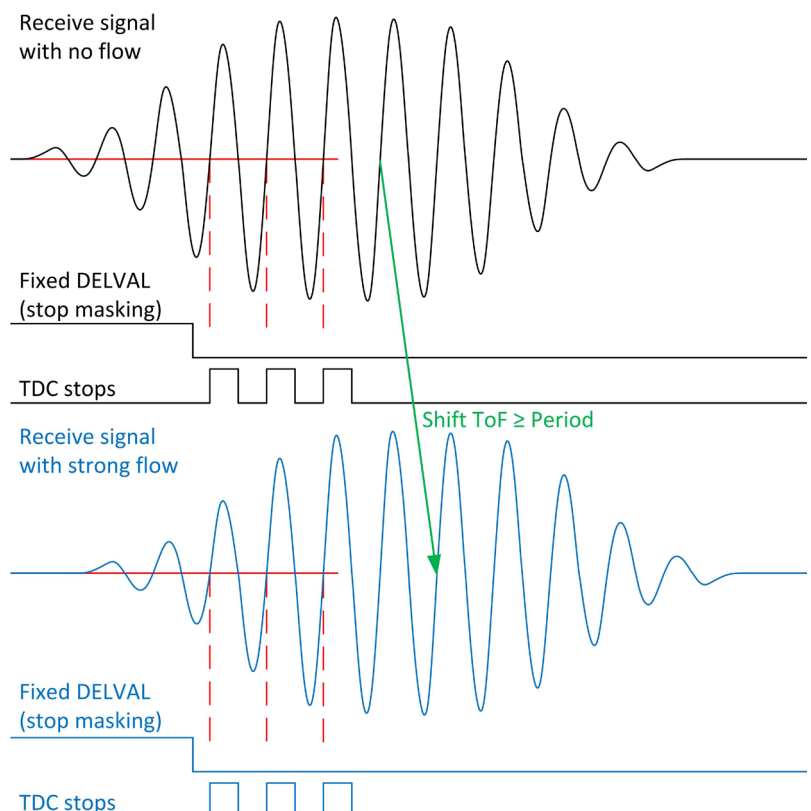

## 4 Converter Frontend

handle intrinsically changes bigger than a signal period.

There is still another source of getting wrong measurements. Dirt deposition on the transducers, spool piece mirrors and housing will lead to signal damping e.g. from  $\pm 400$  mV to  $< \pm 80$  mV. Figure 4-11 shows how this will affect the first wave detection at a given, fixed offset for the first wave detection. Once the first wave amplitude is below the offset level the measurement result will jump by one period.

Figure 4-11: Wrong measurement due to signal damping

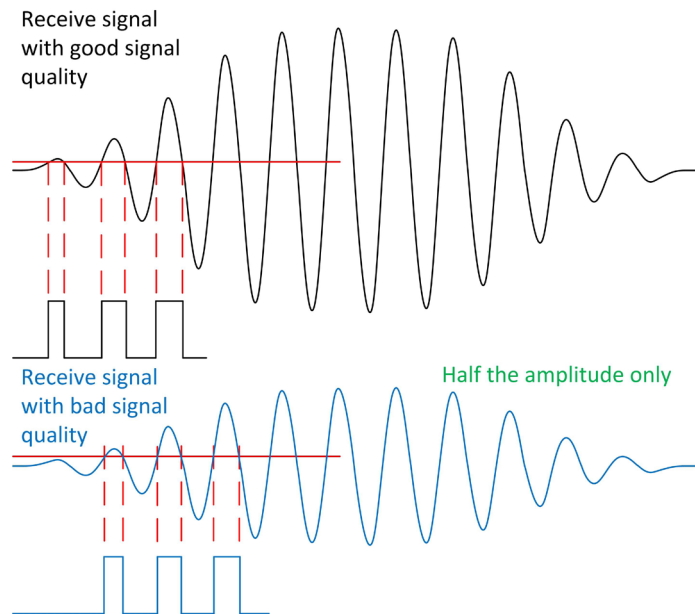

With the TDC-GP22's first wave detection the time-of-flight measurement is related to the first wave and gets independent from temperature and flow. Miscalculations due to wrong zero crossing assignment are no longer possible.

Additionally, the measurement of the width of the first half wave gives the user a chance to monitor the signal quality and to adjust the first wave offset trigger level if necessary.

The following figure shows the new measurement flow in TDC-GP22 first wave mode.

1. With the fire pulse generation the offset for the first wave detection is set to a programmable level. The DELVAL1 stop masking is used for suppressing any noise and it is set just roughly close to the minimum expected time-of-flight. Further noise will be suppressed by the comparator offset until the receive signal reaches the an amplitude above this offset level.
2. The TDC-GP22 measure the time interval between rising and falling edge of the first wave. Then, it automatically sets back the offset to 0 mV. With  $< 1$  mV offset the offset drift of the flow measurement over temperature is minimized.
3. The stop masking for the three time measurements is set by parameters DELREL1 to DELREL3, relative to the first wave. E.g. DELREL1 = 3 says the 3rd wave after the first wave is measured.
4. The half wave period (hwp) of the first true time measurement is measured as a reference for the first wave. In the example from figure 4-12 this would be the width of the 5st wave.

The ratio  $\text{hwp}_{\text{first wave}} / \text{hwp}_{\text{firstToF}}$  is in the range of 0 to 1, typically less than 1. The smaller the va-



## 4 Converter Frontend

Figure 4-12: First Wave Mode

1. Programmable trigger level is set to e.g. +20 mV to get the 2nd wave safely

2. Afterwards, it is set back to 0 mV automatically

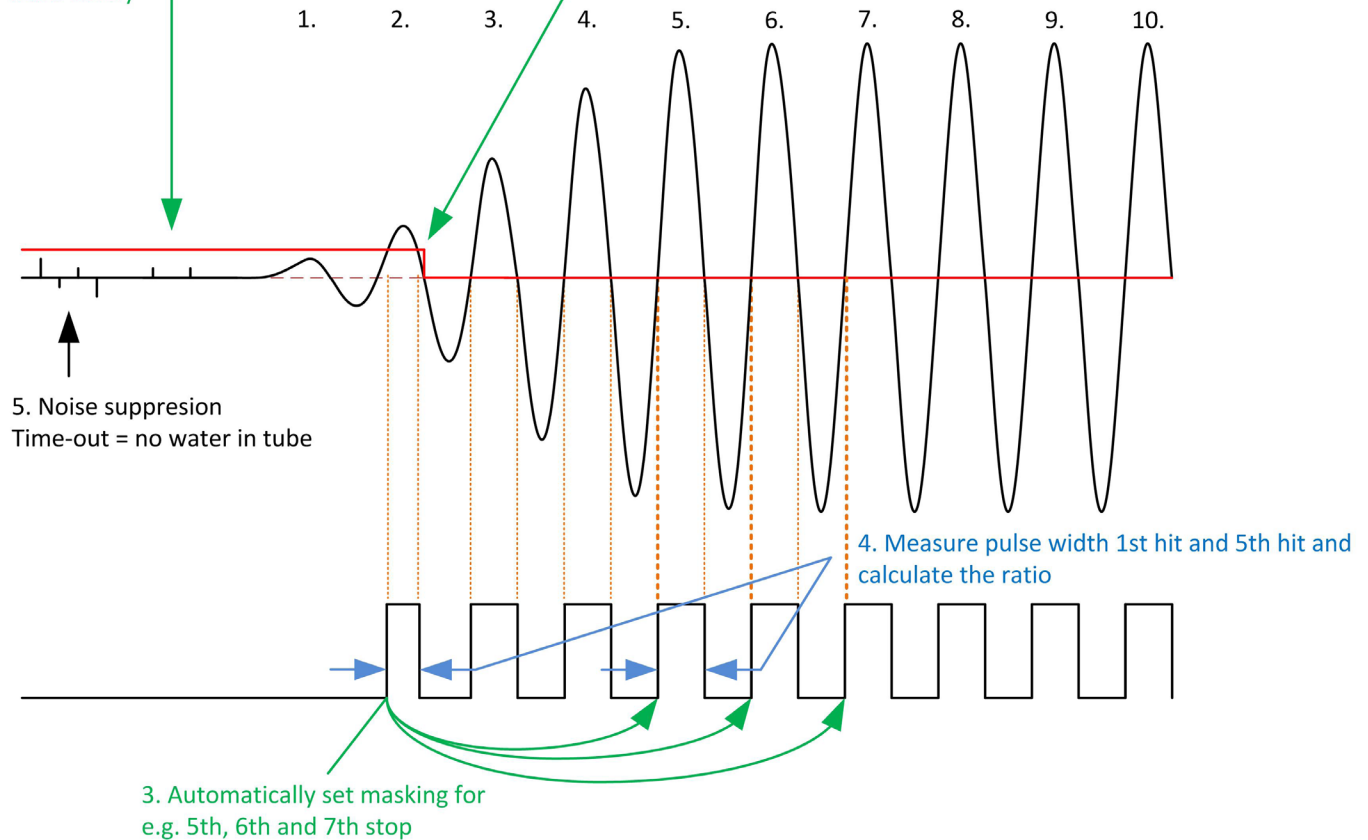

the weaker is the receive signal. The information can be used to monitor the flow meter. If there are too many deposits over the years of operation and the signal ratio drops e.g. below 0.5 then the second wave can be used as reference in the future.

The signal drop might also be caused by bubbles in the water. Therefore, an alarm message can be sent in parallel to the operator.

5. TDC-GP22 automatically calculates all three stop events and further calculates the average of the three which will be available from register 4. This way, the communication with the microprocessor is simplified a lot. As soon as the interrupt is set the processor can immediately read all three results or just the average value. There is no need to re-write register 1 like it was with TDC-GP21.

6. In case the spool piece is empty then there will be no stop signal. The offset will stay at the level for the first wave detection. This way, noise can not trigger the TDC and the TDC will run into a time-out.

In other words: the timeout is an indicator for an empty tube.

## 4 Converter Frontend

### 4.4.1 Configuration

The relevant configuration parameters are:

Table 4-3: First Wave Mode Configuration

Reg.	Bits	Parameter	Description
3	30	EN_FIRST_WAVE	1 = Switches on the First Wave Mode, Reg3, DELVAL2 and Reg4, DELVAL3 get a new meaning.
4	8 - 12	OFFS	2's complement number setting the offset shift in 1 mV steps 0 = 0 mV 1 = +1 mV ... 15 = +15 mV 16 = -1 mV 17 = -2 mV ... 31 = -16 mV
4	13	OFFSRNG1	1 = Additional offset shift by - 20 mV
4	14	OFFSRNG2	1 = Additional offset shift by + 20 mV
3	8 - 25	DELREL1 to DELREL3	Stop masking, select the xth wave for time-of-flight measurement. Maximum is the 63rd wave. DELREL1 $\geq$ 3. DELREL1 to DELREL3 have to be set in ascending order. Example:  DELREL1 = 3, DELREL2 = 4, DELREL3 = 5 means to measure 3rd, 4th and 5th wave after the first wave
4	16	DIS_PW	0 = switch on / 1 = switch off pulse width measurement. The ratio can be read from address 8, register PW1ST as an 8 bit fixed point number with one integer bit (range 0 to 1.99).
4	15	EDGE_FW	Sets the edge sensitivity for the first wave. With a negative offset it is reasonable to trigger on the falling edge of the first wave.  0 = rising edge, 1 = falling edge
3	31	EN_AUTOCALC_MB2	1 = switch on the automatic calculation of all enabled hits. The sum of the results is written to read register 4.

## 4 Converter Frontend

### 4.5 Temperature Measurement

Especially for heat meter applications the TDC-GP22 has a PICO STRAIN based temperature measuring unit that offers high resolution and very low current consumption.

The measurement is based on measuring discharge times. Therefore, a capacitor is discharged alternately through the sense resistors and the reference resistors. As an improvement compared to TDC-GP2, the TDC-GP22 has the comparator already integrated.

Figure 4.13

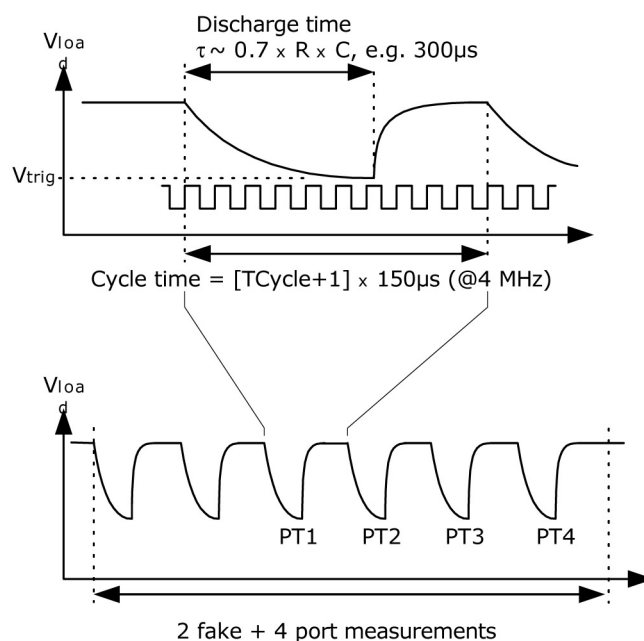

The unit has 4 resistor ports, two of them to be used for the temperature sensors for hot water (up) and cold water (down). The other two ports are used for reference resistors. Basically, on reference resistor connected to both ports is sufficient.

The temperature sensors should have a minimum resistance of 500 Ohm. The cable length should not exceed 3 m. TDC-GP22 can measure 2-wire sensors only. It is not possible to use 4-wire sensors. The precision of the temperature measurement is far within the limits of the standard for heat meters when PT500 or PT1000 are used. In combination with PT500 or PT1000 temperature sensors there is no need for two reference resistors. A typical setup with with one fixed reference is shown in figure 4-14.

With some loss in temperature stability the TDC-GP22 is also capable of temperature measurement with PT100 sensors. In that case we recommend to use two reference resistors instead of one, as shown in figure 4-15. This helps to (partly) overcome the increasing gain drift by means of a two

## 4 Converter Frontend

point temperature calibration over the full temperature range.

Figure 4.14: PT500 / PT1000 temperature measurement with one reference resistor

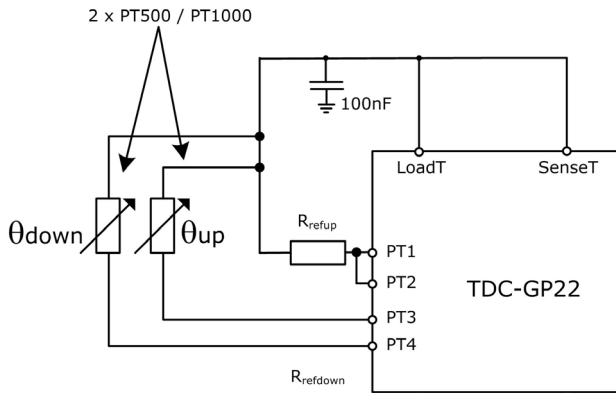
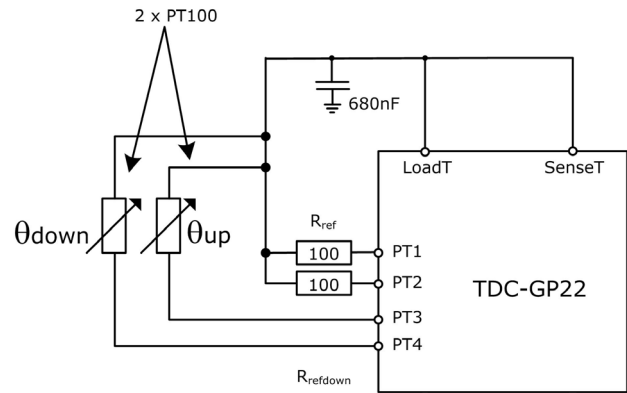

Figure 4.15: PT100 temperature measurement with two reference resistors



The temperature measurement is fully automated. It is triggered by the  $\mu\text{C}$  sending the opcodes Start\_Temp or Start\_Temp\_Restart. With Start\_Temp\_Restart the TDC-GP22 measures the temperature twice, with a delay given in multiples of the 50 Hz/60 Hz period. This will be of help to reduce 50Hz/60Hz noise.

For a measurement, the TDC-GP22 starts with 2 or 8 dummy measurements at port PT1 before it makes the real four measurements in the order PT1 > PT2 > PT3 > PT4. After the 4 measurements have finished the interrupt flag is set. TDC-GP22 has the possibility to inverse the order, making the dummy measurements at port PT4.

The four data are found in registers 0 to 3. From Res\_3/RES\_1 and RES\_4/RES\_2 the microcontroller can calculate the ratio  $R_{\text{temp}}/R_{\text{ref}}$ . By means of a look-up table it can calculate the temperature for the special type of sensor in use.

### Configuration

Register 0, bit 15, ANZ\_FAKE sets the number of dummy measurements at the beginning of a temperature measurement. This is necessary to overcome mechanical effects of the load capacitor.

ANZ\_FAKE = 0            2 dummy measurements

ANZ\_FAKE = 1            8 dummy measurements

Register 0, bit 16, TCYCLE sets the cycle time for the temperature measurement.

TCYCLE = 0            128  $\mu\text{s}$  cycle time @ 4MHz

TCYCLE = 1            512  $\mu\text{s}$  cycle time @ 4MHz

## 4 Converter Frontend

Register 0, bit 17, ANZ\_PORTS sets the number of ports that will be used.

ANZ\_PORTS = 0      2 ports = 1 sensor

ANZ\_PORTS = 1      4 ports = 2 sensors

Register 6, bit 11, TEMP\_PORTDIR sets the order of the port measurements

TEMP\_PORTDIR = 0      PT1 > PT2 > PT3 > PT4

TEMP\_PORTDIR = 1      PT4 > PT3 > PT2 > PT1

Register 6, bit 15, HZ60 sets the base frequency for the delay between the up and down measurements for commands Start\_TOF\_Restart and Start\_Temp\_Restart.

HZ60            = 0            50 Hz base

HZ60            = 1            60 Hz base

Register 6, bits 18,19, CYCLE\_TEMP, selects the factor timer for triggering the second temperature measurement in multiples of 50/60Hz.

CYCLE\_TEMP = 0            1

                 = 1            1.5

                 = 2            2

                 = 3            2.5

Register 6, bit 30, NEG\_STOP\_TEMP inverts the signal at the SenseT path. This is mandatory when the internal comparator is used. Without inversion the unit is compatible to TDC-GP2 operation with an external Schmitt trigger

NEG\_STOP\_TEMP    = 0    No inversion, TDC-GP2 compatible

                         = 1    Inversion, mandatory when the internal comparator is used

### Recommended Capacitor Values

The discharge time should be about 150  $\mu$ s. Therefore the capacitor should have the following value:

PT500:            220 nF

PT1000:          100 nF

Please set Tcycle = 1 to avoid timeout error.

## 4 Converter Frontend

### Recommended Capacitor Type

To get accurate results we recommend capacitor types with very low dC/dU. We recommend:

COG types or CfCap Series from Tayo Yuden

For heatmeter application please do note use X7R or similar capacitors.

### Current consumption

By means of the TDC technology the temperature measurement needs an extremely low current, much less than an A/D converter does.

A full temperature measurement with 2 sensors, 2 references am PT1000 sensor type, including all calculations takes less than 2.5  $\mu$ As. With one temperature measurement in 30 seconds (typical for heatmeters) the average current consumption is 0.08  $\mu$ A only. This is about 50 times less than other solutions. A PT500 sensor doubles the current.

Note: During temperature measurement the start input has to be enabled.

### Error detection

Additionally the temperature unit checks the plausibility of the results. It is able to detect a short circuit of the sensor or an open sensor. The TDC-GP22 provides in the relevant output register an error code instead of a measurement value.

1. Short circuit between lines: equivalent to a very short time interval ( $< 8 \times T_{ref} = 2 \mu s @ 4 MHz$ ). The TDC-GP22 writes a 'h0 to the output register of the shorted sensor.
2. Broken sensor/Short circuit against GND: equivalent to no stop signal or timeout. The TDC-GP22 writes a 'hFFFFFFF into the output register of the open sensor.

Note: Due to a bug it is necessary to have SEL\_TIMO\_MB2 at 2ms to get a correct interrupt indication when 512  $\mu s$  cycle time is selected.

Figure 4-16: Short circuit indication

1: Short circuit between lines: Error short

2: Short circuit LoadT against GND: Error open

3: Circuit circuit PT2 against GND: Measurement at PT1 with half the nominal discharge time as sensor is in parallel to Rref, result out of reasonable range

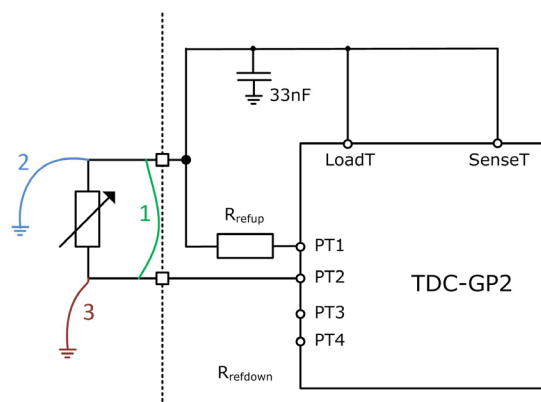

## 4 Converter Frontend

Table 4.4: Analog specification

Symbol	Terminal	Internal Schmitt-Trigger		external Schmitt-Trigger <sup>2</sup>		Unit	
		PT500	PT1000	PT500	PT1000		
	Resolution RMS	17.5	17.5	16.0	16.0	Bit	
	SNR			96	96	dB	
	Absolute Gain <sup>3</sup>	0.9912	0.9931	0.9960	0.9979		
	Absolute Gain vs. Vio <sup>3</sup> (gain factor)	3.6 V	0.9923	0.9940	0.9962	0.9980	
		3.0 V	0.9912	0.9931	0.9960	0.9979	
		2.5 V	0.9895	0.9915	0.9956	0.9979	
	Gain-Drift vs. Vio	0.25	0.23	0.06	0.04	%/V	
	max. Gain Error (@ dθ = 100 K)	0,05%	0,05%	0,02%	< 0.01%		
	Gain-Drift vs. Temp	0.022	0.017	0.012	0.0082	%/10 K	
	Gain-Drift vs. Vio			0,08		%/V	
	Initial Zero Offset	< 20	<10	< 20	< 10	mK	
	Offset Drift vs. Temp	< 0.05	< 0.03	< 0,012	< 0.0082	mK/ °C	
	PSRR			>100		dB	

<sup>1</sup> All values measured at Vio = Vcc = 3.0 V, Cload = 100 nF for PT1000 and 200 nF for PT500 (COG-type)

<sup>2</sup> measured with external 74AHC14 Schmitt-trigger

<sup>3</sup> compared to an ideal gain of 1

### Gain error and its mathematical correction

The TDC-GP22 temperature measurement is based on acam's PICOSTRAIN technology. Here the resistance variation of an RTD is digitized by means of a high accurate time interval measurement. According to that, the Schmitt-trigger's delay time introduces a considerable gain error that results in a gain reduction compared to an ideal output value. This gain reduction can be mathematically described as a deviation from an ideal straight line. Hence, a simple mathematical correction by adding a correction factor compensates for this deviation from the ideal gain. It is calculated as follows:

$$T_{\text{corr}} = T_{\text{uncorr}} / \text{gainfactor}$$

with

## 4 Converter Frontend

$T_{\text{corr}}$ : gain corrected temperature result

$T_{\text{uncorr}}$ : uncorrected temperature result

gainfactor: gain correction factor, compensates the deviation from an ideal gain of 1

By means of this compensation, the effect of the Schmitt-trigger's delay time can be reduced to a residual gain error of 0.05% of F. S. with the internal Schmitt-trigger, or even less in combination with an external 74AHC14 Schmitt-trigger.

Three main parameters have to be considered, to select the correct gain factor:

- base resistance of the temperature sensor (e. g. PT500, PT1000)
- used Schmitt-Trigger (GP22-internal, external 74AHC14)
- GP22 supply voltage

The appropriate gain correction factors are provided in table 4-3 ("Absolute gain vs. Vio").

### Import note:

The gain correction factors for the external Schmitt-trigger exclusively refer to the 74AHC14 Schmitt trigger. Other types (e. g. 74HC14) require different gain factors, in order to ensure a correct compensation. According to that, we strongly recommend to use a 74AHC14 as external Schmitt trigger.

#### Example 1:

Application with PT1000 Sensor, GP22 internal Schmitt trigger and 3.0 V supply voltage. According to table 4.3 a gain factor of 0.9931 has to be selected. The gain corrected result is calculated then by the following equation:

$$T_{\text{corr}} = T_{\text{uncorr}} / 0.9931$$

#### Example 2:

Application with PT500 Sensor, external 74AHC14 Schmitt trigger and 3.6 V supply voltage. Table 4-3 now specifies a gain factor of 0.9980. The gain corrected result is calculated as follows:

$$T_{\text{corr}} = T_{\text{uncorr}} / 0.9980$$



<b>5</b>	<b>Details and Special Functions .....</b>	<b>5-2</b>
<b>5.1</b>	<b>Oscillator .....</b>	<b>5-2</b>
5.1.1	High-Speed Oscillator.....	5-2
5.1.2	32.768 kHz Oscillator .....	5-3
5.1.3	Calibrating a Ceramic High-speed Oscillator.....	5-3
5.1.4	How to use Clock Calibration .....	5-4
<b>5.2</b>	<b>Fire-pulse Generator.....</b>	<b>5-5</b>
5.2.1	General Description.....	5-5
5.2.2	Configuration.....	5-5
<b>5.3</b>	<b>Fast Initialization .....</b>	<b>5-8</b>
<b>5.4</b>	<b>Noise Unit.....</b>	<b>5-8</b>

## 5 Details and Special Functions

### 5.1 Oscillator

The TDC-GP22 uses up to 2 clock signals depending on the operating mode:

- High-speed clock, typically 4 MHz, for calibration and as a predivider for the TDC measuring unit in measure mode 2 and for the EEPROM
- 32 kHz clock signal used for internal timer functions.

#### 5.1.1 High-Speed Oscillator

Generally, the TDC-GP22 needs a high-speed clock for calibration. The recommended value is 4 MHz, the possible range is 2 to 8 MHz (2 to 6 MHz in QUAD\_RES mode). When running in measure mode 2 the TDC-GP22 needs the high-speed clock signal also as a part of the time measuring unit. Finally the operations need the high speed clock, too.

The oscillator takes an average current of 200  $\mu$ A when running all the time. But as it is needed only during the time measurement, the TDC-GP22 has the capability to control the on-time by itself. The settings are done with parameter START\_CLKHS. With START\_CLKHS > 1 the oscillator is switched on after sending opcodes Start\_TOF, Start\_TOF\_Restart, Start\_Temp and Start\_Temp\_Restart for the duration of the measurement. A delay between starting the oscillator and starting the measurement guarantees sufficient time for the oscillation to settle at full amplitude.

START\_CLKHS

= 0	Oscillator off
= 1	Oscillator continuously on
= 2	The measurement is started with 480 $\mu$ s delay.
= 3	same as '2', but with 1.46 ms delay
= 4	same as '2', but with 2.44 ms delay
= 5 to 7	same as '2', but with 5.14 ms delay

Figure 5.1

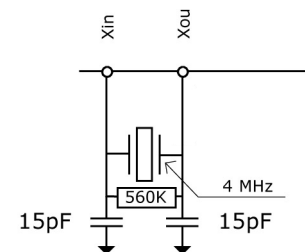

The programmable delay guarantees that the oscillator has settled before the measurement starts. For ceramic resonators 480  $\mu$ s will be sufficient.

By this measure the average current consumption can be drastically reduced.

Example:

At one ToF measurement in an ultrasonic flowmeter (forth/back) per second the high-speed oscillator is active only for about 2 ms. The average current consumption is  $130 \mu\text{As} * 2 \text{ ms} = 0.26 \mu\text{A}$ .

## 5 Details and Special Functions

### 5.1.2 32.768 kHz Oscillator

The TDC-GP22 needs a 32.768 kHz reference for the start-up control of the high-speed clock and the clock calibration. It therefore offers an integrated low-power driver.

The 32.768 kHz oscillator is permanently running and has a current consumption of only about 0.5  $\mu$ A at 3.0 V. The settling time of this oscillator is about 3 s after power-up. The 32.768 kHz oscillator cannot be switched off. Without a 32kHz clock pin CLK32In has to be connected to GND.

The low-power clock can be internally forwarded to an output pin to be available for an external microprocessor. The possible settings are:

SEL\_TSTO1 = 7: 32 kHz output at pin FIRE\_IN

SEL\_TSTO2 = 7: 4 kHz (32kHz/8) output at pin EN\_START

It is also possible to provide an external low-frequency rectangular clock at the CLK32Out pin (3.6 V max.).

### 5.1.3 Calibrating a Ceramic High-speed Oscillator

Using a ceramic oscillator for the 2 to 8 MHz clock will be attractive because it is of low cost and has a fast settling time. Unfortunately it has a poor tolerance of 0.3 to 0.5 % and shows a temperature drift. For this reason the TDC-GP22 allows to execute a calibration measurement that allows to compensate this behavior. This measurement is based on the very precise 32.768 kHz clock. The TDC-GP22 generates start/stop pulses from the 32.768 kHz and measures this time interval with its TDC unit. The result is stored in the result register and the interrupt flag is set. The frequency error of the ceramic resonator can be calculated by the microprocessor. The calibration is configured by setting register O, ANZ\_PER\_CALRES and is started with „START\_Cal\_Resonator“ - instruction by the microprocessor.

The time interval to be measured is set by ANZ\_PER\_CALRES which defines the number of periods of the 32.768kHz clock:

ANZ_PER_CALRES	= 0	2 periods = 61.035 $\mu$ s
	= 1	4 periods = 122.07 $\mu$ s
	= 2	8 periods = 244.14 $\mu$ s
	= 3	16 periods = 488.281 $\mu$ s

Figure 5.2

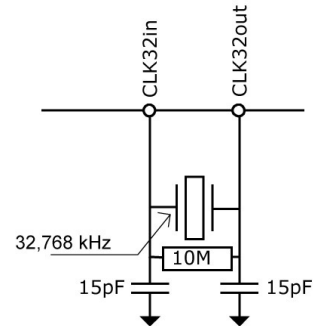

## 5 Details and Special Functions

The results is given in multiples of the high-speed clock and (divided by 1, 2 or 4 (DIV\_CLKHS)) as 32 bit fixed point numbers with 16 integer bits and 16 fractional bits.

The microcontroller can compare this measured value to the theoretical value and calculate the correction factor  $RES\_X/RES_{theor}$ .

Example:

The system shall work with a 4 MHz resonator. With  $CLKHSDIV=0$  and  $CALRES\#=1$  the theoretical result is  $122.0703125\mu s/250ns = 488.28125$  ( $RES\_O = 'h01E84800$ ). If the ceramic resonator in use is not exactly at 4MHz but only 3.98MHz the calibration measurement will show 485,83984375 ( $RES\_O = 1E5D700$ ). The correction factor for the microcontroller is 1.005.

**Note:** During clock calibration the start input has to be enabled.

### 5.1.4 How to use Clock Calibration

#### a. Application

This option is dedicated especially to ultrasonic flow and heat meters. In those applications the use of ceramic oscillators shows two main advantages: lower cost and less current consumption. Mainly because of the short oscillation start-up time of the ceramic oscillator the operating current can be reduced by several  $\mu A$ . Referring to 10 years of operation this saves several 100 mAh in battery capacitance. There is no negative effect on the resolution when using this option the correct way.

#### b. Jitter of the 32 kHz clock and consequences

The 32 kHz clock is very precise in frequency with only a few ppm error. However, the phase jitter is about 3 to 5 ns peak-peak. For this reason also a calibration measurement (Start\_Cal\_Resonator) has this error. When multiplying a measurement result with the calibration result, the jitter of the calibration is transferred to the result by the ratio calibration measurement time (see CALRES#) to measurement time. Using a permanently updated calibration value will add a considerable jitter to the measurement result.

#### c. Application of this option in ultrasonic flow meters

A measurement result is always made of two single time-of-flight measurements in ultrasonic flow meters, with and against the flow direction. The difference between those measurements is a measure for the flow. To avoid an influence of the calibration jitter on this measurement result it is necessary only to use the same calibration for both ToF measurements. Following this, the difference between the two ToF measurements will be free of the jitter of the clock calibration measurement. The clock can be calibrated only between measurements that are not directly subtracted from each other.

## 5 Details and Special Functions

### 5.2 Fire-pulse Generator

#### 5.2.1 General Description

The fire-pulse generator generates a sequence of pulses which is highly programmable in frequency, phase and number of pulses. The high-speed oscillator frequency divided by the factor selected for CLKHS\_DIV is used as the basic frequency. This frequency is internally doubled and can freely be divided by a factor of 2 to 15. It is possible to generate 1 to 127 pulses. If maximum 15 pulses are sent the phase for each pulse can be adjusted per register configuration. The fire-pulse generator is activated by sending opcode Start\_Cycle. The firepulse maybe used directly for the START of the TDC.

The fire-pulse generator provides 2 outputs, FIRE\_UP and FIRE\_DOWN. The driver strength of each output is 96 mA @3.3 V. Furthermore, FIRE\_DOWN output signal can be inverted to double the signal amplitude. The outputs can be set individually high-Z. Alternately, the default level of the inactive buffer can be set to GND.

The fire-pulse generator allows to generate and send pulse sequences multiple times for use in a quasi “sing-around” method. Using this feature the received pulse sequence is fed into TDC-GP22 FIRE\_IN input. It is digitally amplified and directly forwarded to the output buffer for an immediate re-emittance without any clock delay. This option can not be used with the internal analog section.

#### 5.2.2 Configuration

##### Number of pulses:

ANZ_FIRE	= 0	Switch off fire-pulse generator
	= 1	1 pulse
	= 2	2 pulses
	...	...
	= 127	127 pulses
SEL_START_FIRE	= 1	Fire pulse is used as TDC START
FIRE_DEFAULT	= 0	Default level High_Z (GP2 compatible)
	= 1	Default level GND. Mandatory if the internal analog circuit and the recommended circuit with external R and C is used.

##### Phase:

The phase of each pulse can be defined in register 5, Bits 0 to 15, PHFIRE, if not more than 15 pulses are sent. „0“ stands for HIGH-LOW and „1“ for LOW-HIGH. The pulse sequence begins with the

## 5 Details and Special Functions

LSB and ends with the MSB

Example:

Fire# = 7, PHFIRE = 'h0055

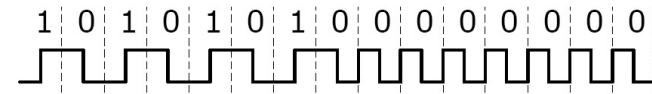

### Fire-pulse frequency:

The input signal fireclk1 for the fire pulse generator is derived from the high speed clock CLKHS and the selected value for the high speed clock divider DIV\_CLKHS.

Figure 5.3

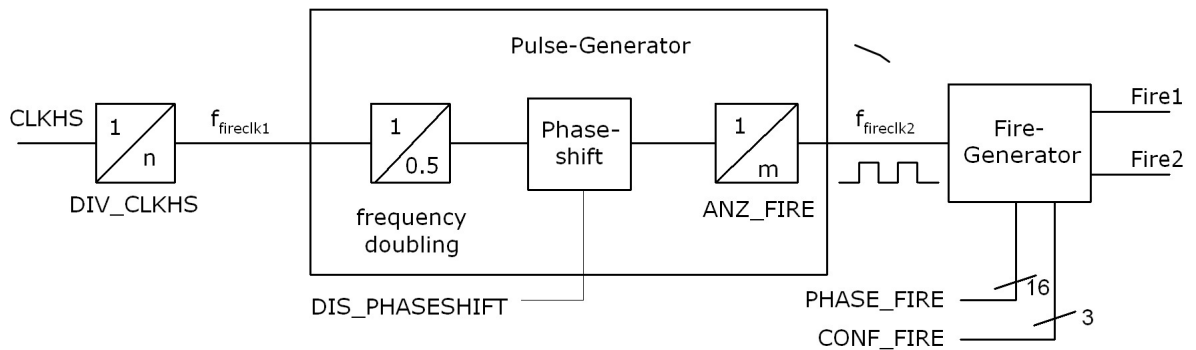

This Signal is internally doubled and divided by DIV\_FIRE.

DIV_FIRE =	0	not permitted
	1	divided by 2
	2	divided by 3
	...	...
	15	divided by 16

Register 5, Bit 19, DIS\_PHASESHIFT activates the phase shift, which introduces additional noise to improve statistical behaviour when averaging.

DIS\_PHASESHIFT = 0 Phase shift on

DIS\_PHASESHIFT = 1 Phase shift off

$$f_{\text{fireclk2}} = f_{\text{fireclk1}} \times \frac{2}{\text{DIV\_FIRE} + 1}$$

## 5 Details and Special Functions

fireclk2 is used as reference signal for the FIRE\_UP / FIRE\_DOWN - signal which is emitted by the output buffers FIRE\_UP / Fire 2 of the fire pulse generator.

Figure 5.4

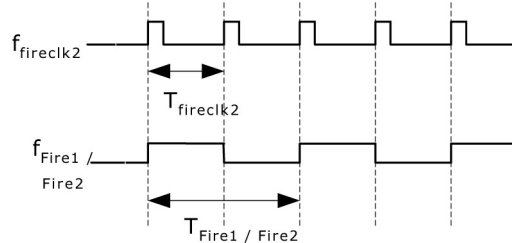

As shown in Figure 16 at least 2 clock periods  $T_{fireclk2}$  are required to send one Fire\_Pulse. One for the high phase and one for the low phase of the FIRE\_UP/FIRE\_DOWN output signal.

Example:

CLKHS = 4 MHz, DIV\_CLKHS = 1, DIV\_FIRE = 1

$$f_{fireclk2} = f_{fireclk1} \times \frac{2}{DIV\_FIRE + 1} = 2 \text{ MHz}$$

Max. frequency of the FIRE\_UP / FIRE\_DOWN output signal:

$$f_{Fire1/Fire2} = \frac{1}{2} \times f_{fireclk2} = 1 \text{ MHz}$$

### Driver outputs:

The output drivers are configured in register 5, Bits 29 to 31, CONF\_FIRE:

Bit 31 = 1                      FIRE\_BOTH (Inverted output on FIRE\_DOWN)

Bit 30 = 1                      FIRE\_Up enabled

Bit 29 = 2                      FIRE\_DOWN enabled

Pulse-burst repetition (quasi sing-around):

In register 5, Bits 16 to 18, REPEAT\_FIRE the number of repetitions of the pulse sequence is defined.

REPEAT\_FIRE = 0      no repetition

                  = 1      1 repetition

                  ...      ...

                  = 7      7 repetitions

Only the number of pulses set under FIRE# will be repeated. With a period of 5  $\mu$ s without a pulse the TDC-GP22 detects the end of a pulse sequence.

## 5 Details and Special Functions

### Note:

This option can not be used with the internal analog section. It is strongly recommend that the summarized time of flight of the up to 7 repetitions does not exceed the measurement range of the GP22 !!!

### 5.3 Fast Initialization

In measurement range 1 the TDC-GP22 offers the possibility of a fast initialization. Activated by setting register 1, Bit 15, EN\_FAST\_INIT = „1“ the interrupt flag automatically initializes the TDC. So the TDC is already prepared for the next measurement while the data can be read out. This mode is for highest speed applications only. It is most reasonable for un-calibrated measurements with only one stop.

### 5.4 Noise Unit

In case the user wants to improve the measuring results by averaging it is necessary that the values do not always display exactly the same time difference. Instead the user should provide some ‚noise‘ so that different quantization steps of the characteristic curve of the TDC are involved. This can not happen with very constant time differences. One would constantly hit the same LSB.

The noise unit enables the use of weighted averaging even for constant time differences. The noise unit adds a random offset to the start. It is dedicated to applications where the TDC gets a dummy start and measures the time difference between STOP1 and STOP2 (e.g. laser range finders).

The noise unit is switched on by setting register 5, Bit 20, EN\_STARTNOISE = „1“



<b>6 Applications .....</b>	<b>6-2</b>
<b>6.1 Ultrasonic Heat Meter .....</b>	<b>6-2</b>



## 6 Applications

### 6.1 Ultrasonic Heat Meter

The TDC-GP22 is perfectly suited for low-cost ultrasonic heatmeter designs. Thanks to the implemented functionality, including precision temperature measurement, fire pulse generation, analog switches, comparator, windowing and clock calibration, it is sufficient to add a simple microprocessor (without A/D converter).

The final circuit reaches a unknown level in compactness and small size. The following diagram shows the front end section of a typical ultrasonic heat meter as it might look like when TDC-GP22 is used.

Figure 6.1

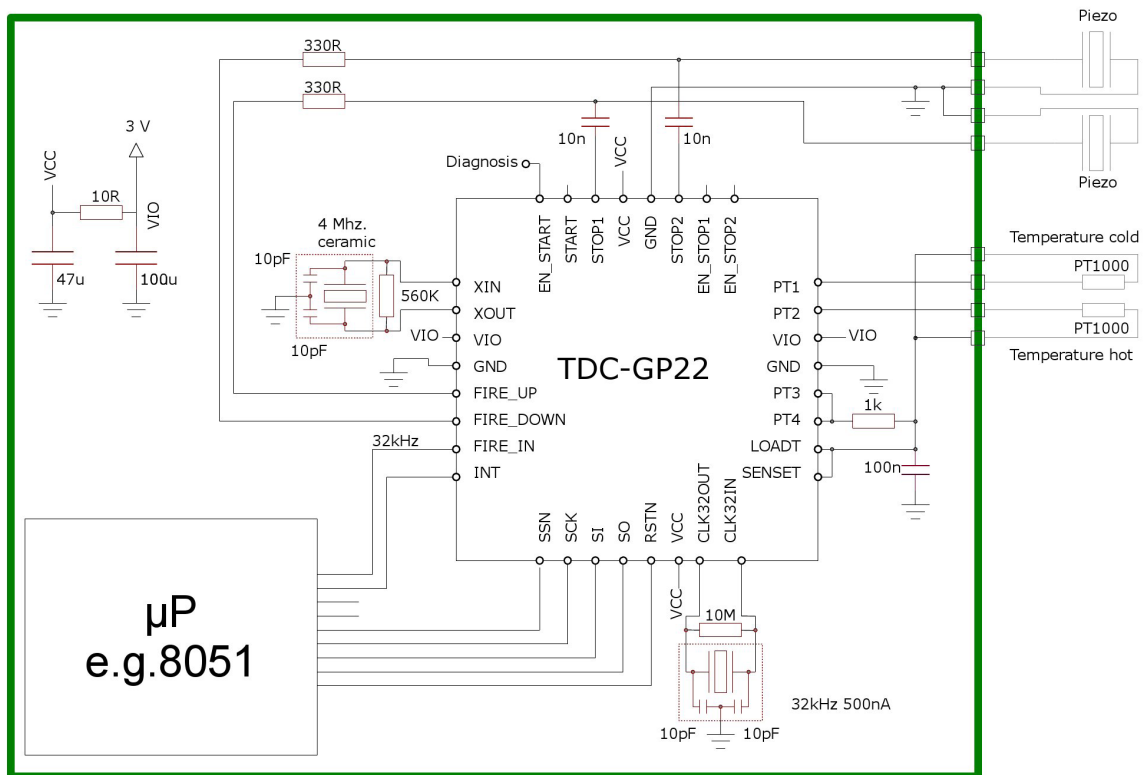

The red parts illustrate the external components needed. The number is reduced to a minimum:

- In the ultrasonic path, the piezo transducers are connected through pairs of R and C.
- In the temperature path only a temperature stable reference resistor and a capacitor
- As oscillators take a 32.768 kHz and a ceramic 4 MHz oscillator. The FIRE\_IN pin can be used as output driver for the 32.768 kHz clock, so the µP does not need a low power oscillator.
- For the power supply use separate bypass capacitors of sufficient size to block VCC and VIO. Separate both by a small resistor.

In total 11 low-cost elements only are needed for the measurement.

## 6 Applications

Register	Value	Typical example configuration
Register 0	'hA30B6800	ANZ_FIRE = 10 (see register 6, too) DIV_FIRE = 3, fire pulse frequency = 4 MHz/4 = 1.0 MHz ANZ_PER_CALRES = 0, the 4 MHz is calibrated by a 61.035µs measurement DIV_CLKHS = 0, the 4 MHz ceramic oscillator is internally used as it is START_CLKHS = 2, the ceramic oscillator has 480 µs to settle ANZ_PORT = 1, use all 4 ports for the temperature measurement TCYCLE = 1, 512 µs cycle time for the temperature measurement ANZ_FAKE = 0, 2 fake measurements SEL_ECLK_TMP = 1, use 4 MHz for the temperature measurement cycle definition CALIBRATE = 1, mandatory in measure mode 2 to be on NO_CAL_AUTO = 0, mandatory in measure mode 2 to have auto-calibration MESSB2 = 1, switch on measure mode 2 for measuring > 2 µs. NEG_STOP/NEGSTART = 0, all set to rising edges ID0 = h00
Register 1	'h21444000	HIT2 = 2, HIT1 = 1: calculate 1. Stop - Start in measure mode 2 EN_FAST_Init = 0, off HITIN2 = 0 HITIN1 = 4, measure 3 stops (in measure mode 2 this includes the start, too, giving 4 hits) CURR32K = 0, use default SEL_START_FIRE = 1, use the internal direct wiring from the fire pulse buffer to the TDC start SEL_TSTO2 = 0, EN_START active SEL_TSTO1 = 0, FIRE_IN pin is used as fire in ID1 = h00
Register 2	'hA0230000	EN_INT = b0101, interrupt given by time_out, ALU ready or Timeout RFEDGE1 = RFEDGE2 = 0, use only rising edges DELVAL1 = 8960, the first stop is accepted after 70 µs ID2 = h00
Register 3	'hD0510300	EN_AUTOCALC = 1, automatic calculation of all 3 hits EN_FIRST_WAVE = 1, first hit detection mechanism is enabled EN_ERR_VAL = 0, there is enough time to read the status register SEL_TIMO_MB2 = 2, time out is generated after 1024 µs DELREL1 = 3, DELREL2 = 4, DELREL3 = 5, measure the 3rd, 4th and 5th stop after the first hit ID3 = h00

## 6 Applications

Register 4	'h20004A00	<p>DIS_PW = 0, pulse width measurement is not disabled</p> <p>EDGE_PW = 0, pulse width measured on rising edge</p> <p>OFFSRNG1 = 0, no negative offset</p> <p>OFFSRNG2 = 1, OFFS = 10: total offset = 20 mV + 10 mV = 30 mV</p> <p>ID4 = h00</p>
Register 5	'h40000000	<p>CON_FIRE = 2, disables FIRE_UP, FIRE_DOWN = enable. If opcode Start_TOF_Restart is used FIRE_UP and FIRE_DOWN are used alternately for up and down flow measurements. The configuration described here then starts the measurement cycle with a down flow measurement (FIRE_DOWN = enable).</p> <p>EN_STARTNOISE = 0, switch off</p> <p>DIS_PHASESHIFT = 0, phase noise unit is active to improve the statistical behaviour</p> <p>REPEAT_FIRE = 0, no sing-around</p> <p>PHASE_FIRE = 0, no phase change in the fire pulse sequence</p> <p>ID5 = h00</p>
Register 6	'hC0C06000	<p>EN_ANALOG = 1, use the internal analog circuit</p> <p>NEG_STOP_TEMP = 1, use the internal Schmitt trigger for the temperature measurement</p> <p>DA_KORR = 0, offset is set in register 4</p> <p>TW2 = 3, 300 µs delay to charge up the capacitors of the highpass</p> <p>EN_INT = b1101, interrupt given by time_out, ALU ready or end of EEPROM action (see also register 6)</p> <p>START_CLKHS = 2, the ceramic oscillator has 480 µs to settle (see also register 0)</p> <p>CYCLE_TEMP = 0, use factor 1.0 for the Start_Temp_Restart</p> <p>CYCLE_TOF = 0, use factor 1.0 for the delay between two TOF measurements</p> <p>HZ60 = 0, 50 Hz base</p> <p>FIREO_DEF = 1, mandatory when using the internal analog circuit</p> <p>QUAD_RES = 1, use 23 ps BIN</p> <p>DOUBLE_RES = 0</p> <p>TEMP_PORTDIR = 0, standard order for T measurement</p> <p>ANZ_FIRE = 10 (see register 0, too)</p> <p>ID6 = h00</p>

## 6 Applications

### Measurement flow:

Power-on reset:

Send SO = 'h50

Calibrate Clock:

Send SO = 'h03 Start\_Cal\_Resonator

Check-loop INTN = 0?

Send SO = 'hB0, Read SI = RES\_0

Correction factor =  $61.035 / \text{RES}_0$

### Measurement loop:

Temperature measurement, every 30 seconds:

Send SO = 'h02 Start\_Temp

Check-loop INTN = 0?

Send SO = 'hB4, Read SI = STAT

STAT & 'h1E00 > 0: -> Error routine

Send SO = 'hB0, Read SI = RES\_0

Send SO = 'hB1, Read SI = RES\_1

Send SO = 'hB2, Read SI = RES\_2

Send SO = 'hB3, Read SI = RES\_3

$R_{\text{hot}} / R_{\text{ref}} = \text{RES}_0 / \text{RES}_1$

$R_{\text{cold}} / R_{\text{ref}} = \text{RES}_3 / \text{RES}_2$

Go to look-up table to get the temperature.

Time-of-flight measurement every half second:

Send SO = 'h70 Initialize TDC

Send SO = 'h05 Start\_TOF\_Restart

Check-loop INTN = 0? (up TOF)

Send SO = 'hB4, Read SI = STAT

STAT & 'h0600 > 0: -> Error routine, timeout = empty tube.

Send SO = 'hB3, Read SI = RES\_3

Send SO = 'h70 Initialize TDC

Check-loop INTN = 0? (down TOF)

Send SO = 'hB4, Read SI = STAT

STAT & 'h0600 > 0: -> Error routine

Send SO = 'hB3, Read SI = RES\_3

$\mu\text{P}$  can now start the data post-processing and calculate the flow and the heat.

Check signal strength via pulse width:

Send SO = 'hB8, Read SI = PW1ST

If PW1ST < 0.3 signal is too weak, alarm

### 6.2 Ultrasonic Water Meter

## 6 Applications



## 7 Miscellaneous

### 7.1 Bug Report

#### 7.1.1 TDC-CAL read error without Quad resolution

In case quad resolution is not set then reading separately the TDC cal value will give a wrong read value. The internal calibration value is correct, but the transfer to the read register is not correct. Therefore, measurement data are not affected.

Effect in Measure mode 2:

- In this mode the cal value is for information only. Further, quad resolution is recommended anyway.

Effect in Measure mode 1:

- Customers using autocalibration are not affected.
- Only customers that want to read uncalibrated data and do external calibration are affected.

Workaround:

- The calibration data are not addressed directly after the calibration measurement but after the next regular measurement, before the next INIT.

Example:

```
Reg2 = 'h2144...
```

```
Reg2 = 'h7644...
```

```
result0 = read(adr=0)
```

```
cal = read(adr=1)
```

```
INIT
```

#### 7.1.2 Timeout Temperature Measurement

Note: Due to a bug it is necessary to have SEL\_TIMO\_MB2 at 2ms to get a correct interrupt indication when 512  $\mu$ s cycle time is selected.

### 7.2 Last Changes

19.08.2011	Version 0.0
02.11.2011	Version 0.0 for release
27.01.2012	Version 0.1 for release, sections 6 and 7 modified
29.03.2012	Version 0.3 for release, 7.1.2 new, registers 1 and 4 corrected

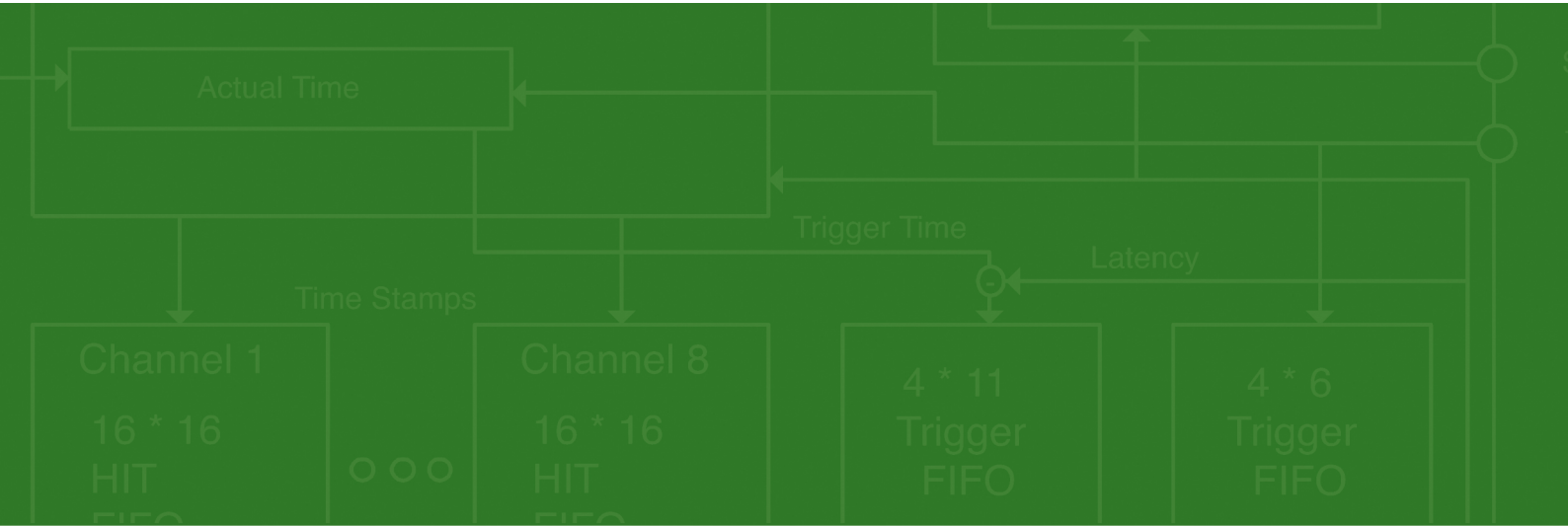

acam-messelectronic gmbh  
Friedrich-List-Str. 4  
76297 Stutensee-Blankenloch  
Germany / Allemagne  
ph. +49 7244 7419 - 0  
fax +49 7244 7419 - 29  
e-mail: support@acam.de  
www.acam.de